

ENERGY REQUIREMENTS FOR GARLIC JUICING

EL-GAYAR, S.M.*

ABSTRACT

This study was carried out during 2013 season at El- Dakahlia Agricultural experiments administration, Agric. Res. center, in Mansoura city, El- Dakahlia Governorate. A pressing cell device was designed and constructed to provide a data base for garlic josses designers and identify the effect of some factors on the required energy for garlic juicing. For each one of Baladi and Sidth-40 cultivars, an experiment was established and design statistically as a factorial design in three replicates. The tested treatments were piston weight (0.12, 0.17 and 0.22 kN), piston plate surface configuration (smooth and notched) and clove moisture content (61.91, 66.64 and 68.09 and 62.48, 67.59 and 68.95% (d.b.) for Baladi and Sidce-40 cultivars, respectively. The obtained results could be summarized as follows:

- 1- 0.22 kN piston weight of notched plate surface using Baladi and Sidce-40 clove moisture content levels of 61.91 and 62.48% achieve higher elasticity degree values of 0.3 and 0.26 respectively.*
- 2- 0.22 kN piston weight of notched plate surface using Baladi and Sidce-40 clove moisture content levels of 68.09 and 68.95% achieve higher clove permeability coefficient and higher juice compressibility values of 37 and 52 mm/kPa and 53 and 58 N/min respectively.*
- 3- 0.22 kN piston weight of notched plate surface using Baladi and Sidce-40 clove moisture content levels of 61.91 and 62.48% obtained lower specific energy juicing values of 25.08 and 20.57 kN.mm/g, respectively.*

Finally, it is recommended to apply higher level of piston weight of notched plate surface using lower level of clove moisture content to achieve lower specific energy for garlic juicing.

* **Senior Researcher at the Ag. Eng. Res. Inst. (AEnRI), Giza.**

INTRODUCTION

Garlic products are being promoted in the form of volatile oils, juices, extracts in liquid and dried forms and macerates for utilization in pharmaceuticals and food preservation. Series of garlic juice biological benefits have been mainly attributed to the antioxidative activity. They are antiatherosclerotic, antihypertensive, antimicrobial, anticancer, immunomodulation, and radioprotection (**Zeng et al., 2008**).

To extract garlic juice, the fresh garlic is milled to obtain a medium structured mash. Then the mash is pumped into a buffer tank where it is left for 15–60 min to complete enzymatic reactions. Juice extraction is done either by pressing or decantation. The juice is adjusted to the desired pH and passed through preheated. The juice is sterilized for few seconds after preheating (**Santhosha et al. 2013**).

Expression is the process of mechanically removing liquid contained in solids by the use of equipment such as screw presses, hydraulic presses, roll presses and mills. It yields a chemical free protein-rich meal that is simple in construction and easy to operate and maintain. It can be applied at room temperature. So, it maintains the natural product quality. It is not time/ mass dependent; it acts instantaneously, thus reducing the processing time. Once the desired pressure is reached, it can be maintained without the need for further energy input. It is environment friendly since it requires only electric energy and there are no waste products. But it affords low-yield (**Willems et al., 2008, Kartika et al., 2010 and Boutin et al., 2011**).

Mechanical expression energy is considered as an important parameter influencing the expression process efficiency. It depends to great extent on the material physical and mechanical properties (**Frame, 1994 and Godavarti and Karwe, 1997**).

This current work aimed to study the effect of some operational factors on the required energy for garlic juicing.

MATERIAL AND METHODS

Experimental Procedure:

To fulfill the objective of this study, an experiment was carried out during 2013 season at El- Dakahlia Agricultural experiments administration, Agric. Res. Center, in Mansoura city, El- Dakahlia Governorate.

An amount of 3 kg of selected garlic cloves of both Baladi and Sidth-40 cultivars were graded manually and grouped into three categories as follows:

- 1- Fresh cloves.
- 2- Naturally dried cloves.
- 3- Rewetted cloves.

These categories were stored in refrigerator using polyethylene bags at 4°C and 90% relative humidity until testing to obtain an uniform moisture content. To proceed this study, the garlic cloves were taken from the refrigerator and left to temper in the polyethylene bags at room temperature of 27± 2 °C for 2 hrs. As indicated in table (1), according to **Mohsennin (1986)**, some characteristics of each category were determined before testing.

Table (1): Some garlic Baladi and Sidth-40 cultivars characteristics:

Characteristics		Moisture content, db%	Length , mm	Width , mm	Thickness, mm	Surface area,mm ²	Weight , g	Firmness , N
Baladi	Fresh	66.64	28.19	11.03	9.03	219.27	0.91	17.10
	Dried	61.91	26.86	10.83	8.82	189.79	0.83	15.50
	Rewetted	68.09	28.97	11.98	9.59	240.95	1.13	18.80
Sidce-40	Fresh	67.59	28.69	12.02	11.02	265.17	2.46	18.20
	Dried	62.48	27.19	11.73	10.59	217.59	2.01	16.90
	Rewetted	68.95	29.64	12.91	11.64	291.64	2.91	19.60

Pressing cell device:

As shown in Figs. (1 and 2), a pressing cell device was designed, constructed and used as an uniaxial press device. It consists of the following components:

- 1- Frame: The pressing cell is fixed using a frame which was manufactured from welded steel angles of 0.55, 0.23 and 0.03 m in length, width and thickness, respectively. The frame is supported by 3 legs.
- 2- Hydraulic lever: It produces a compression force with a speed of 15 mm/ min and a nominal capacity of 18 kN and accuracy of $\pm 5\%$ full scale.
- 3- Loading piston: It consists of a cylindrical steel bar of 0.025 m diameter. The bar upper end is fastened to a steel plate of 0.01 m diameter where the hydraulic lever is placed. The bar lower end is threaded to the comprehensive load. It moves up and down inside a hollow steel cylinder of 0.027 m diameter and 0.20 m height.
- 4- Cylindrical bore of 0.21m diameter through which the loading piston compresses the sample.
- 5- A steel sieve of 0.5 m mesh diameter is fastened to the bore bottom.

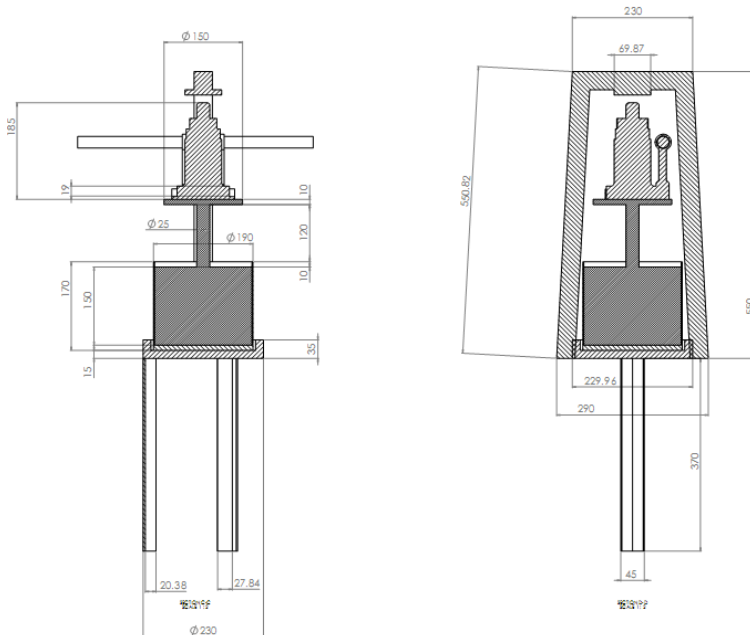

Fig. (1) A schematic diagram of pressing cell device.



Fig. (2) A photograph of pressing cell device.

Treatments and statistical design:

For each one of garlic cultivars, an experiment was carried out to test the following treatments:

- 1- Piston weight: It includes piston weight levels of 0.12, 0.17 and 0.22 kN.
- 2- Piston plate surface configuration: It includes piston plate surface configuration levels of smooth and notched.
- 3- Clove moisture content: It includes fresh, dried and rewetted clove moisture content levels as shown in table (1).

Each experiment was carried out and design statistically as a complete randomized factorial design in three replications.

Measurements:

Clove elasticity degree:

According to **Mohsenin (1986)** and **Baryeh (1990)**, the elasticity degree is determined by compressing 25 cloves to 90% of its original thickness.

The test is stopped when the cloves released. The clove elasticity degree is calculated as follows:

$$D_e = \frac{D_r}{D_c} \quad (1)$$

Where:

D_e is the elasticity degree.

D_r is the piston displacement when the cloves are released, mm.

D_c is the piston displacement when the cloves are compressed, mm.

Clove permeability coefficient and juice compressibility:

According to **Bargale et al (1999)**, a clove is compressed at 15 mm/min compressing speed. As the compressed load is attained, the relaxation mode is started. As the strain is held constant, the clove thickness is measured, then, the clove permeability coefficient (mm/kPa) and compressibility (N/min) are determined.

Energy requirements for garlic juice expression:

A sample of 25 garlic cloves is poured upon a steel sieve. The loading piston is moved down until contacting the sample. When the applied pressing pressure is attained, the test is stopped and the piston displacement reading on the lever is recorded. The compressed cloves are removed from the pressing cell gently and its dimensions are measured. Also, the expressed garlic juice is collected in a container and weighted. According to **ASAE (1995)**, from the typical force-deformation curve for the compressed garlic cloves, the juicing energy requirements is determined directly by measuring the area under the force-deformation curve.

Specific energy for garlic juicing:

The specific energy for garlic juicing (SEGJE) is calculated as follows:

$$SEGJE = \frac{\text{Energy requirement for garlic juice expression}}{\text{garlic juice amount}} \quad \text{N mm/g} \quad (2)$$

Statistical Analysis:

SAS computer software is used to carry out the analysis of variance test for specific energy garlic juicing data. L.S.D. test is applied to show the difference between treatments.

Regression and Correlation Analysis:

Microsoft Excel 2010 computer software is used to perform the simple regression and correlation to show the relation between the specific energy for garlic juicing and both the piston weight and the clove moisture content.

RESULTS AND DISCUSSIONS

Clove Elasticity Degree:

Data in fig. (3) reveal that the piston weight of 0.22 kN of notched plate surface using clove moisture content levels of 61.91 and 62.48% for Baladi and Sidce-40 cultivars achieve higher elasticity degree values of 0.3 and 0.26 respectively. This finding may be illustrated that higher load of notched plate surface enclose material molecules, resulting in higher clove stiffness.

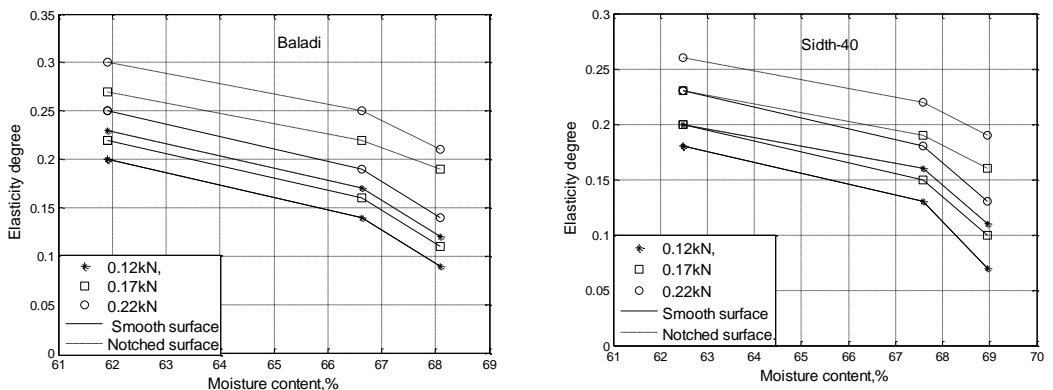

Fig. (3): Effect of clove moisture content on elasticity degree under different levels of piston weight.

Meanwhile the reversible relation between the elasticity degree and the clove moisture content is due to the water higher adhesion properties. This phenomenon is explained that water is in contact with hydroxyl

groups on the cellulose chains that are hydrophilic; that is, surfaces that have a strong attraction to water. Then, the clove stiffens decreases with the moisture content So, Baladi clove elasticity degree values are higher than the corresponding values of Sidce-40 clove.

Clove Permeability Coefficient and Juice Compressibility:

Figs. (4 and 5) clarify that the piston weight of 0.22 kN of notched surface using Baladi and Sidce-40 clove moisture content levels of 68.09 and 68.95% achieve higher clove permeability coefficient values of 37 and 52 mm/kPa and higher juice compressibility values of 53 and 58 N/min respectively. The effect of piston weight on both clove permeability coefficient and clove juice compressibility could be explained that when the clove is subjected to a compressive stress, it exhibits a rearrangement of solid particles, then, Cell walls may have already been ruptured, resulting in expulsion of juice from pores. Meanwhile, the clove porosity increased with the moisture content due to the higher material plastic properties, leading to the higher values of both clove permeability coefficient and juice compressibility. This finding illustrates that Sidce-40 clove achieves permeability coefficient and juice compressibility values higher than the corresponding values of Baladi clove. The notched plate surface achieves higher clove permeability coefficient and juice compressibility values than smooth one. It is explained that the notches facilitate compression, resulting in higher material porosity and increasing the materials pores.

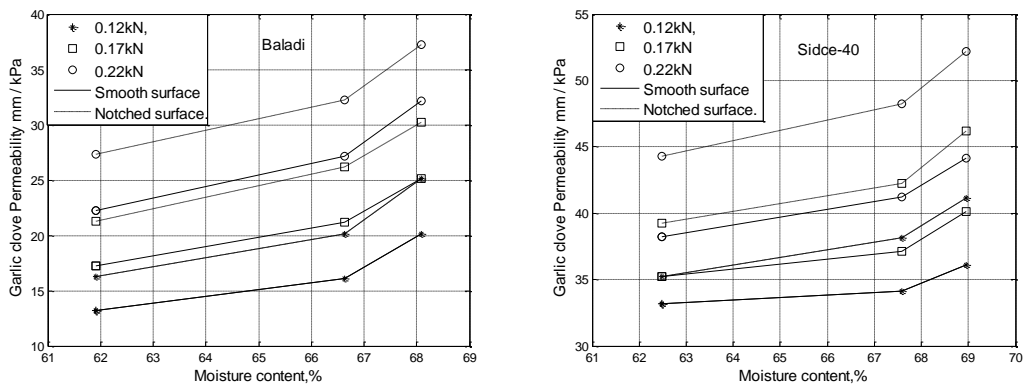

Fig. (4): Effect of clove moisture content on permeability coefficient under different levels of piston weight.

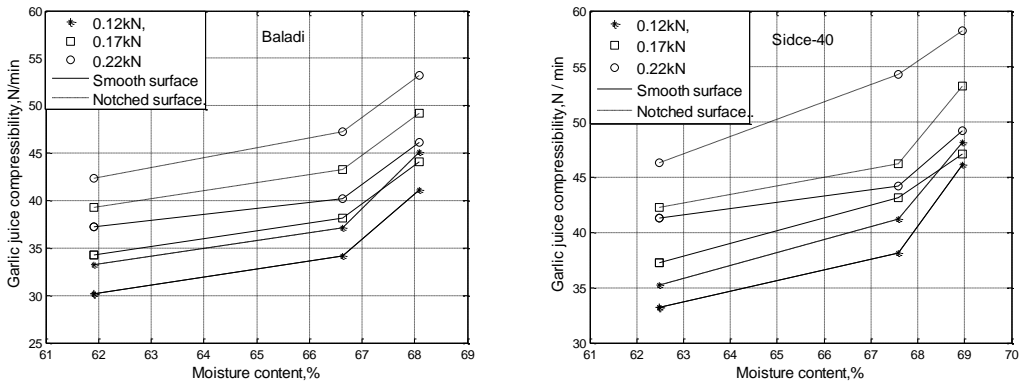

Fig. (5): Effect of clove moisture content on juice compressibility under different levels of piston weight.

Energy Requirements for Garlic Juicing:

As presented in Fig. (6 and 7), force versus deformation curves show that the compression force increases until reaching initial rupture, then it inclines till achieving completely juicing. The figure shows that 0.22 kN piston weight of notched and smooth surfaces using 61.91 % Baladi clove moisture content record the lower forces required for clove deformation to initial rupture of 8.3 and 8.8 kN, respectively. Then, they achieve the lower required forces of 1.9 and 0.7 kN to complete garlic juicing, respectively. So, the lower energy requirements for Baladi juicing of 38.03 and 30.09 kN.mm are found at the previous treatments with the same respect. While, the smooth and notched surfaces record the lower forces required for Sidce-40 clove deformation to initial rupture of 10.6 and 11.2 mm at 0.22 kN piston weight and 62.48 % moisture content respectively. The previous treatments obtained the lower required forces of 2.9 and 2.9 kN for completely garlic juicing, respectively. Hence the previous treatments achieve the lower energy requirements for Sidce-40 juice expression of 55.71 and 59.66 kN.mm with the same respect. This finding may be attributed to the lower clove rupture resistance which is accompanied with piston weight and clove moisture content using notched plate surface.

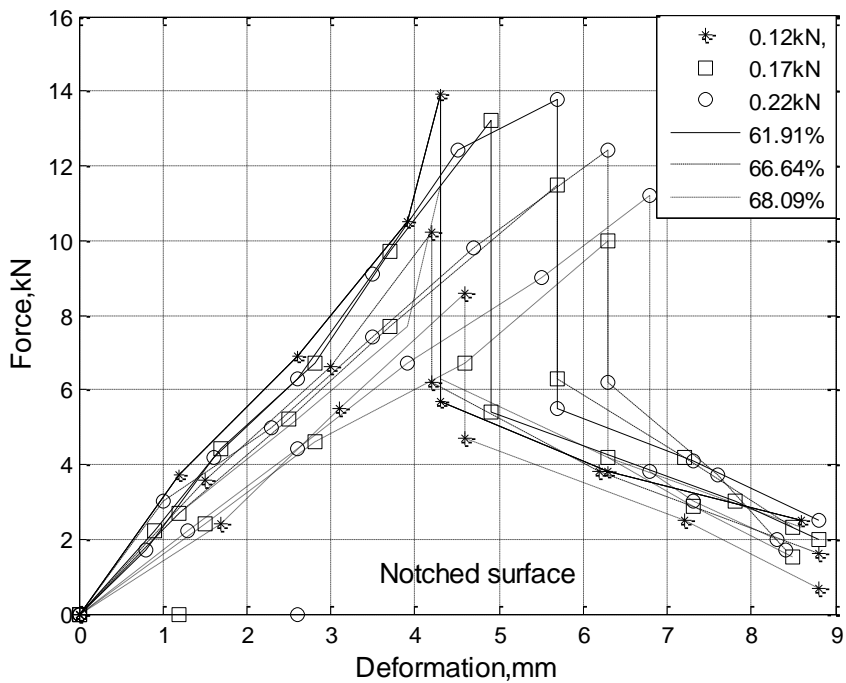
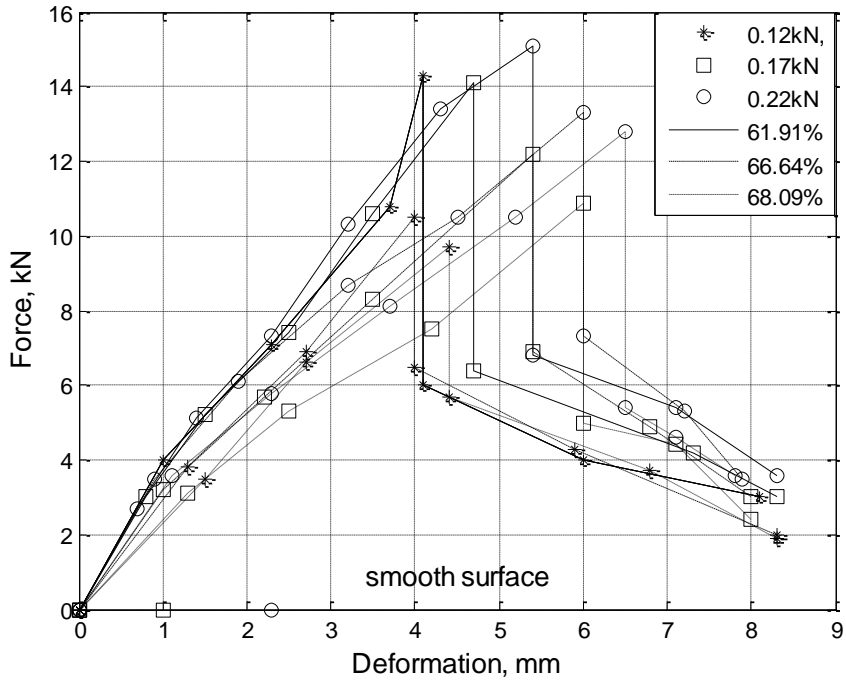

Fig. (6): Force-deformation curve for Baladi cloves.

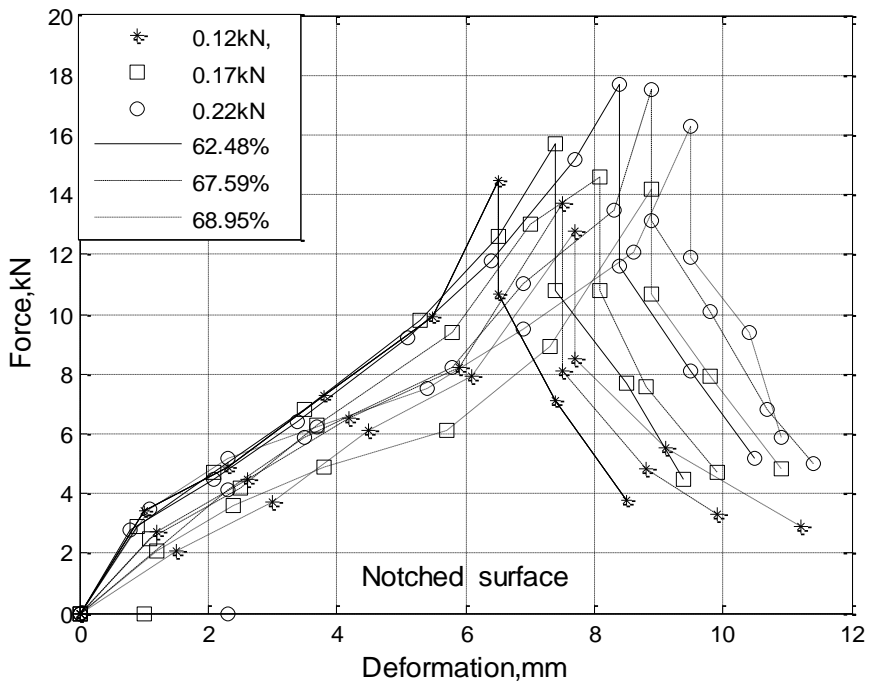
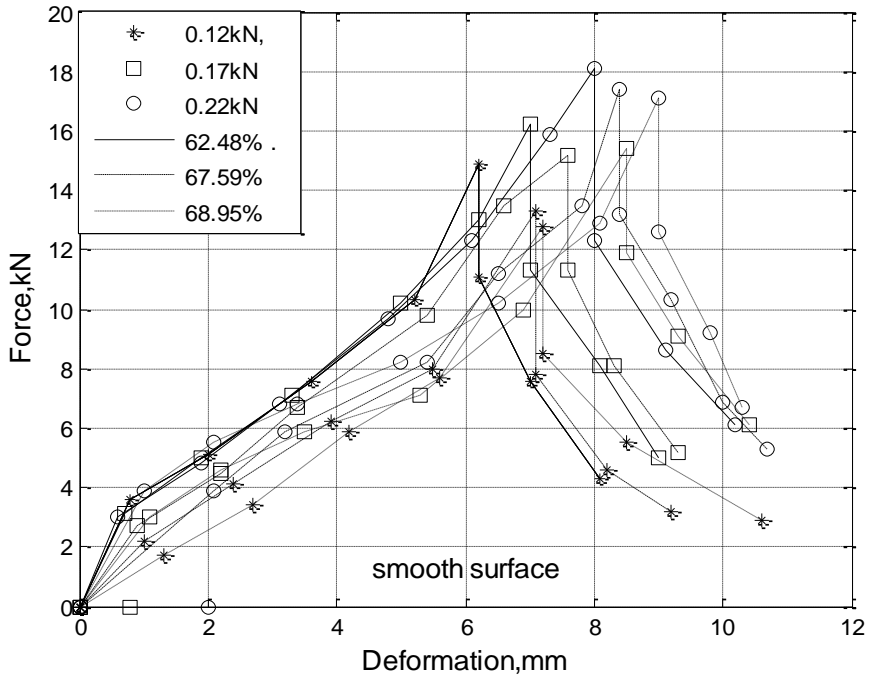

Fig. (7): Force-deformation curve for Sidce-40 cloves.

Specific Energy for Garlic Juicing:

Fig. (8) reveals that 0.22 kN piston weight of smooth and notched plate surfaces using 61.91% Baladi clove moisture content record the lower specific energy juicing values of 48.76 and 25.08 kN.mm/g. While, 0.22 kN piston weight of smooth and notched plate surfaces using 62.48% clove moisture content achieve the lower values of specific energy for sidce-40 juicing of 29.32 and 20.57 kN.mm/g.

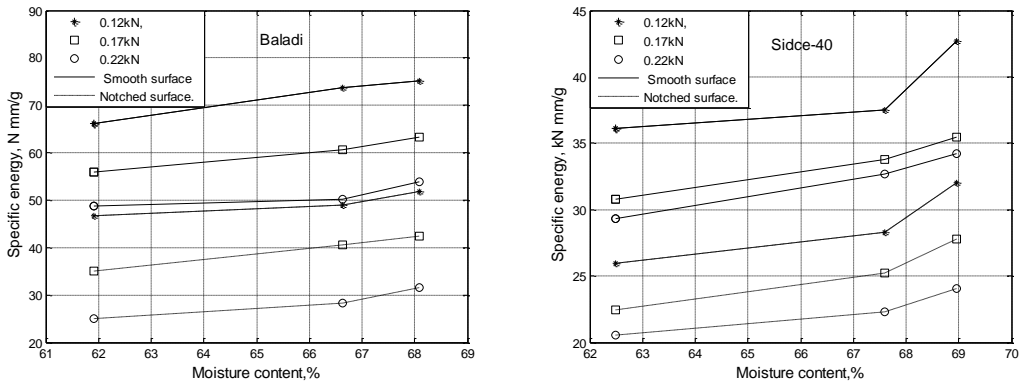

Fig. (8): Effect of clove moisture content on specific juicing energy under different levels of piston weight.

The analysis of variance test of a specific energy for garlic juice expression shows that there is a significant difference between treatments due to piston Weight, plat surface configuration and clove moisture content. L.S.D. test at 5% level indicates that:

- 1- 0.22 kN piston weight and 61.91 % Baladi clove moisture content using smooth and notched plate surface achieve higher significant different among other treatments.
- 2- 0.22 kN piston weight and 62.48 % Sidce-40 clove moisture content using smooth and notched plate surface achieve higher significant different among other treatments.

Simple regression and correlation test shows that there is a positive relation between specific energy for garlic juice expression (y) and clove moisture content (x) as follows:

- 1- Baladi clove

a- Smooth surface:

1. 0.12 kN piston weight: $y = 1.51 x - 27.13$ ($R^2 = 0.9954$).
2. 0.17 kN piston weight: $y = 1.16 x - 16.11$ ($R^2 = 0.9828$).
3. 0.22 kN piston weight: $y = 0.71 x + 4.47$ ($R^2 = 0.7413$).

b- Notched surface:

4. 0.12 kN piston weight: $y = 0.72 x + 2.26$ ($R^2 = 0.8726$).
5. 0.17 kN piston weight: $y = 1.19 x - 38.37$ ($R^2 = 0.9998$).
6. 0.22 kN piston weight: $y = 0.95 x - 34.19$ ($R^2 = 0.9245$).

2- Sidce-40 clove

a-Smooth surface:

7. 0.12 kN piston weight: $y = 0.82 x - 15.31$ ($R^2 = 0.6430$).
8. 0.17 kN piston weight: $y = 0.68 x - 11.73$ ($R^2 = 0.9730$).
9. 0.22 kN piston weight: $y = 0.73 x - 16.43$ ($R^2 = 0.9858$).

b-Notched surface:

10. 0.12 kN piston weight: $y = 0.81 x - 24.64$ ($R^2 = 0.8065$).
11. 0.17 kN piston weight: $y = 0.75 x - 24.70$ ($R^2 = 0.9173$).
12. 0.22 kN piston weight: $y = 0.48 x - 9.64$ ($R^2 = 0.9013$).

CONCLUSION

The obtained results were summarized as follows:

- 1- Piston weight and notched plate surface affected positively each of clove elasticity degree, clove permeability coefficient and juice compressibility.
- 2- Clove moisture content affected inversely clove elasticity degree. and related positively with both clove permeability coefficient and juice compressibility.
- 3- . The clove elasticity degree values at notched plate surface are higher than the corresponding values of smooth one.
- 4- Baladi clove elasticity degree values are higher than the corresponding

values of Sidce-40 clove.

- 5- Both clove permeability coefficient and juice compressibility were related positively to each of piston weight and clove moisture content.
- 6- Sidce-40 clove achieves permeability coefficient and juice compressibility values higher than the corresponding values of Baladi clove. The notched plate surface achieves higher clove permeability coefficient and juice compressibility values than smooth one.
- 7- Specific energy for garlic juice expression related inversely with piston weight and positively with clove moisture content.
- 8- Notched plat surface achieve lower specific energy for garlic juice expression than smooth surface.

Generally, it is recommended to apply higher piston weight levels accompanied with lower clove moisture content levels using notched plate surface to achieve lower specific energy for garlic juice expression.

LITERATURE SITED

- ASAE (1995)** "Standard Engineering Practices Standards(42 nd Edn). American Society of Agricultural Engineers.
- Baryeh, E.A. (1990)** " Rheological Properties of cocoyam. The Agricultural Engineer, 45(4): 118-122.
- Boutin, O.; A.D. Nadaï ; A.G. Perez; J.H. Ferrasse; M. Beltran and E. Badens (2011).** Experimental and modelling of supercritical oil extraction from rapeseeds and sunflower seeds" chemical engineering research and design 8: 2477–2484.
- Bargale, P.C.; R.J. Ford; D. Wulfsohn; J.Irudayaraj and F.W. Sosulski (1999).** Measurement of consolidation and permeability properties of extruded soy under mechanical pressing" J. Agric . Engng Res. 74: 155-165.
- Frame, N.D. (1994).** The technology of extrusion cooking" Glosgow, Blockie

Academic and professional.

- Godavarti s.and Karwe v., (1997)** "Determination of specific mechanical energy distribution on a twin – screw extruder. J. agric. Engn. Res. 67: 277-287.
- Kartika, I.A.; P.Y. Pontalier AND L. Rigal (2010).** Twin-screw extruder for oil processing of sunflower seeds: Thermo-mechanical pressing and solvent extraction in a single step" Industrial Crops and Products 32: 297–304.
- Mohsennin, N. N. (1986)** Physical Properties of Plant and Animal Material.(2nd. Edn). Gordon and Breach Science Publishers, New York
- Santhosha, S.G.; P. Jamuna AND S.N. Prabhavathi (2013).** Bioactive components of garlic and their physiological role in health maintenance: A review" Food Bioscience 3: 59–74.
- Willems, P.; N.J.M. Kuipers and A.B. de Haan (2008).** Gas assisted mechanical expression of oilseeds: Influence of process parameters on oil yield" J. of Supercritical Fluids 45, 298–305.
- Zeng, T.; F.F. Guo; C.L. Zhang; S. Zhao; D.D. Dou; X.C. Gao and K.Q. Xie (2008.)** The anti-fatty liver effects of garlic oil on acute ethanol-exposed mice" Chemico-Biological Interactions. 176: 234–242.

الملخص العربي

متطلبات الطاقة لعصر الثوم

صفية مصطفى الجيار*

أجريت هذه الدراسة خلال موسم ٢٠١٣ بأدارة التجارب الزراعية بالدقهلية , مركز البحوث الزراعية, بمدينة المنصورة – محافظة الدقهلية لتقديم قاعدة بيانات معلوماتية للقائمين على تصميم آلات عصر الثوم حتى يمكن دراسة تأثير بعض عوامل التشغيل على الطاقة اللازمة لعصر الثوم. وقد تم تنفيذ تجربة صممت إحصائياً كتجربة عاملية في ثلاثة مكررات لكل من صنفى البلدى وسدس – ٤٠. وشملت معاملات الدراسة وزن المكبس (٠,١٢, ٠,١٧, ٠,٢٢ كيلو نيوتن) وشكل صفيحة المكبس (ملساء, مشرشرة) ومحتوى رطوبة الفص (٦١,٩١, ٦٦,٦٤, ٦٨,٠٩%) للسنف البلدى و(٦٢,٤٨, ٦٧,٥٩, ٦٨,٩٥%) للسنف سدس-٤٠

* باحث أول بمعهد بحوث الهندسة الزراعية – مركز البحوث الزراعية – الجيزة

ويمكن تلخيص النتائج المتحصل عليها كالتالى:

١. حقق المكبس ذو وزن ٠,٢٢ كيلو نيوتن وذو السطح المسنن عند محتوى رطوبى ٦١,٩١% للفصوص البلدى و مستوى رطوبى ٦٢,٤٨% للفصوص سدس-٤٠ أعلى قيم لدرجة المرونة بمقدار ٠,٢٦ و ٠,٣٠ على التوالى.
 ٢. حقق المكبس ذو وزن ٠,٢٢ كيلو نيوتن والسطح المسنن عند مستوى رطوبى ٦٨,٩٥% للفصوص سدس-٤٠ أعلى قيم لمعامل نفاذية الفص وأنضغاطية العصير ٥٢ مم/كيلو بسكال و ٥٨ نيوتن/ دقيقة على التوالى ٠ بينما المكبس ذو وزن ٠,٢٢ كيلو نيوتن والسطح المسنن عند مستوى رطوبى ٦٨,٠٩% للفصوص البلدى يحقق أعلى قيم لمعامل نفاذية الفص و أعلى أنضغاطية العصير ٣٧ مم/كيلو بسكال و ٥٣ نيوتن/دقيقة على التوالى.
 ٣. حقق المكبس ذو وزن ٠,٢٢ كيلو نيوتن والسطح المسنن و محتوى رطوبى ٦١,٩١ و ٦٢,٤٨% لفصوص الثوم البلدى وسدس-٤٠ أقل طاقة نوعية لعصر الثوم بمقدار ٢٠,٠٨ و ٢٥,٥٧ كيلو نيوتن/مم/جم على الترتيب.
- ولذا فإنه يوصى باستخدام المكبس ذو وزن ٠,٢٢ كيلو نيوتن والسطح المسنن لتحقيق أقل طاقة نوعية لعصر الثوم للفصوص البلدى وسدس-٤٠.