

PERFORMANCE EVALUATION OF A MILLING MACHINE FOR PRODUCING BROILER PELLET CRUMBLES

Hanan, M.S. El-Shal*

ABSTRACT

The goal of this study is evaluating some operating parameters affecting performance of a roller mill and the particle size distribution during producing broiler crumbled feeds (CF) from poultry pellets for the phase of starter. These pellets were manufactured from standard formulation including ingredients with percentages that recommended to the broiler starter. The performance of the milling machine was evaluated under operational variables including; four different roller rotational speeds of 350, 400, 466.67 and 560 rpm corresponding to 2.75, 3.14, 3.66 and 4.40 m/s, three roll clearances of 1.5, 2.5 and 3.5 mm, three feeding rates of 1.3, 4.1 and 6.8 Mg/h. The performance of the machine was evaluated taking into consideration the machine capacity, particle size distribution of the CF, and energy requirement. The obtained results reveal that, it is recommended to use the roller mill at roll speed of 466.67 rpm (3.66 m/s), feeding rate of 6.80 Mg/h and roll clearance of 1.50 mm to achieve the best CF particle size distribution (<1 mm= 19.45%, >1 mm= 29.46%, >2mm= 38.64% and >3 mm=12.45 %) that suit the broiler in the phase of starter at machine capacity of 5.650 Mg/h and consumed energy of about 0.476 kW.h/Mg.

Keywords: roller mill, broiler, crumbled feeds, particle size distribution, roll clearance

INTRODUCTION

It is Known that the most of recent investigations are focusing on how to minimize the total cost of the broiler production by reducing the losses and consequently the cost of the processing operations of the manufactured feeds such as pellets, crumbles or even mash feed. Moreover, selecting the proper diet in the acceptable phase of broiler could improve the feed conversion and enhance the growth performance.

*Lecturer, Agric. Eng. Dept., Fac. of Agric., Zagazig Univ., Egypt.

The cost of feed is a primary concern to the poultry industry since it is compromises about 60-70 % of the total cost of broiler production (**Banerjee, 1998**). The physical form of feed (mash, pellet and crumble) is a key factor in meat yield of broiler (**Mohamed and Talha, 2012**). The feeding of pellets improves feed conversion broiler performance (**Behnke, 1994**) with an increased feed intake (**Nir et al., 1995**). Reasons for the enhanced performance may be due to increased digestibility, decreased ingredient segregation, decreased feed wastage, reduction of energy during prehension and improved palatability (**Behnke, 1998**). There are three growing phases of the broiler, the starter (0-14 day), the grower (15-35 day) and the finisher (35-42 day). The final body-weight performance is positively correlated with early growth rate (e.g. 7-day body weight); thereby ensuring chicks get off to a good start is critical (**Aviagen, 2014**). Crumbles is become a convenience method for enhancing the growth performance the starter broiler is a type of feed prepared at the mill by pelleting of the mixed ingredients and then crushing the pellet to a consistency coarser than mash (**Jahan et al., 2006**). Two processing methods are commonly used to reduce the particle size of the grains; the hammer mill and the roller mill (**Waldroup, 1997**). Reducing feed particles to a finer size requires greater energy use and lowers production rate. Thus, any reduction in energy consumption from grinding could significantly lower feed cost (**Dozier, 2002**). Roller mills are more efficient and require less energy for grinding than the hammer mill also, the roller mill produces a more uniform particle size distribution with lower a proportion of fines than the hammer mill (**Nir and Ptichi, 2001**). Due to the significantly lower energy cost per ton, the roller mill offers an overall lower cost. Regarding these advantages, this study is concerning to utilize the roller mill for crumbling the pellets to feed the broiler starter in attempt to reduce the consumed energy with most appropriate particle size distribution of the crumbled feed. So, the objectives of this study are:

- 1- Evaluating a local made roller mill for crumbling the processed pellets to feed the broiler starter.
- 2- Studying some operating parameters affecting performance of the roller mill and the particle size distribution that suit the broiler starter.

3- Determining the consumed energy of the roller mill during crumbling process.

MATERIALS AND METHODS

The practical experiments were performed in a private poultry pellet feed factory at Abou Hammad district, Sharkia Governorate to evaluate the performance of a roller mill for producing broiler (Starter) crumbles.

A-Materials:

-The poultry pellets:

The poultry pellets were manufactured using a ring die pelleting with diameter of 3 mm and length of 6 mm. The die of the pelleting machine with 200 mm in diameter and 40 mm in thickness was operated at speed of 350 rpm, whereas the roller diameter was 90 mm. The moisture was added to the formulation as steam in the conditioner. The percentages of the ingredients in the broiler starter formulation are given in Table (1).

Table (1): The ingredients of the broiler starter formulation

Ingredients	Percentage,%
Yellow Corn	58.50
Soy Meal	30.50
Soy oil	2.50
Dicalcium	1.80
Calcium Carbonate	0.97
Salt	0.25
Vit/Minerals	0.30
Gluten	4.58
Methionine	0.20
Lysine	0.20
Threonine	0.10
Antitoxin	0.10
Total	100

-The roller mill:

The roller mill was used to crumbling the produced pellets to reduce their size because the broiler starter feeds, and often the first delivery of broiler grower feeds, are usually crumbles. The construction features of the

milling machine mainly consists of the following parts as shown in Figs.(1 and 2):

- The machine hopper and frame

It is a galvanized steel hopper with trapezoidal sectional profile with 3 mm in thickness, 2.5mm in length, 1125.mm at top and 875mm at bottom with width of 675mm at top and 550 mm at bottom and 220 mm in depth. There is a folding gate at the bottom of the hopper to control flow rate of the pellets that passing through it, in addition to assure the longitudinal distribution of pellets along the crushing rolls. Regarding frame, it is a robust rectangular box frame that made of steel with geometric dimension of 1175 L×550 W×725D mm, which accommodate a pair of crushing rolls and secure their position during operating.

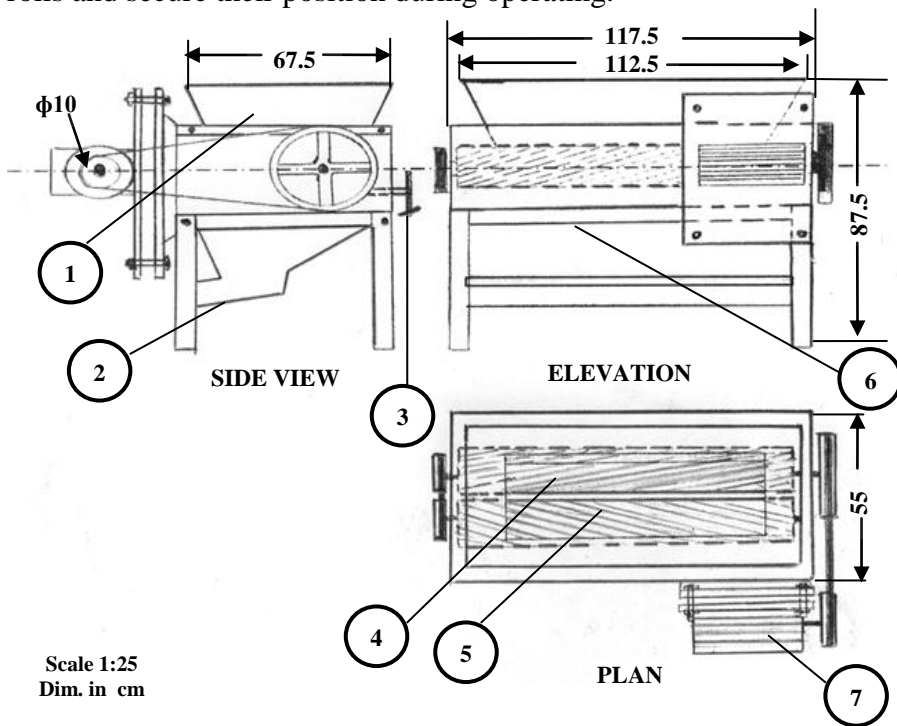

(1) Feed hopper, (2) Outlet chute, (3) roll clearance adjustment screw, (4) Drive roll, (5) Driven roll, (6) Frame, (7) Electric motor.

Fig. (1): Elevation, plan and side view of the roller mill.

- Crushing rolls

The milling machine consists of two steel corrugated in parallel and tram rolls (as shown in Fig.3-a) with 150 mm in diameter and 1100 mm in

length, where one of the rolls (drive roll) received the motion from an electric motor from one side of the frame, while the opposite one (driven roll) takes its rotational motion from the drive roll at the other side of frame by using pulley and belts transmission unit. The roll corrugation can be described as roll fluting, where the two rolls were corrugated circumferentially with grooves known as the LaPage ring cut and it can featured as classical LaPage ring cut, as shown in Fig.(3-b). The clearance between two rolls can be adjusted through pressing on the driver roll by perpendicular screw, while the opposite roll remained fixed.



Fig.(2): View of the roller milling machine.

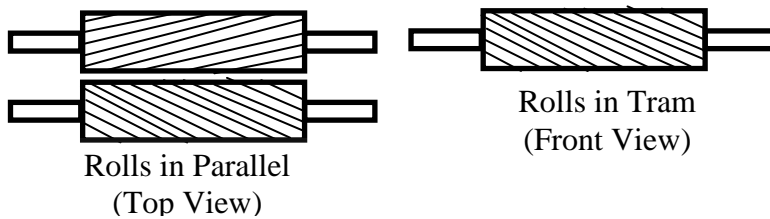

a- The rolls position within machine

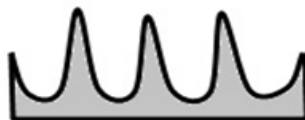

b- The LaPage ring cut profile

Fig. (3): The shape, position and grooves profile of rolls.

- Power Unit

The power unit including electric motor that fixed on the machine frame with rated power of 5 kW at 1400 rpm rotational speed. It was used to operate the drive roll through pulley and belt unit. In this study four pulley's diameters were used of 250, 300, 350 and 400 mm to obtain four roll rotational speeds of 350, 400, 466.67 and 560 rpm, respectively , as shown in Fig.(4).

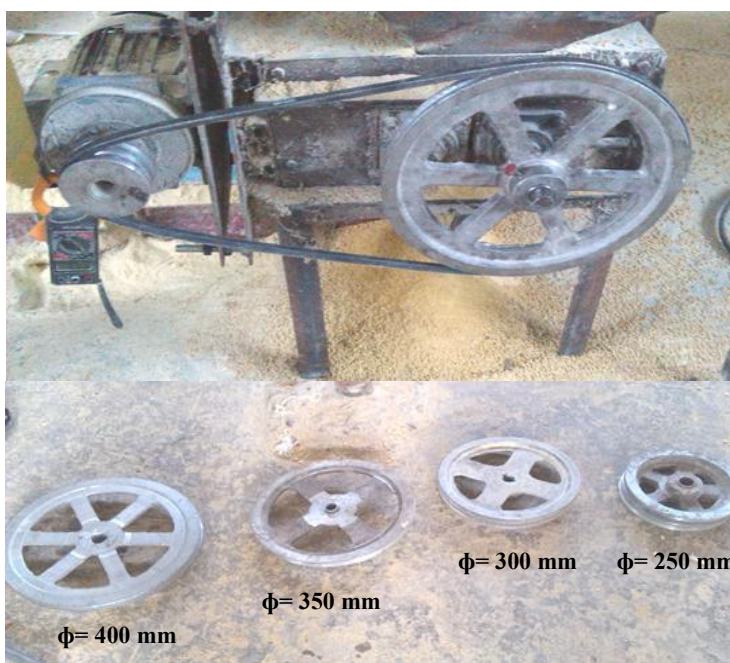

Fig.(4): The transmission unit using different pulley's diameters.

- Crumbles Sieving

Motorized, sieve shaker (HUMBOLDT .MFG .Co, USA, Model: H-4325) with dimension of 380 x 380 x 1143 mm uses a 1/4 hp electric motor with a 30-minute timer. In this study, four sieves of 0.5, 1, 2, 3 mm plus the cover and pan were used to determine the particle size distribution in the crumbled feed (CF), as shown in Fig.(5).

B-Methods:

The practical experiments were carried out to select the proper operating parameters affecting the performance of the roller mill, these parameters are:

- 1- Four roll speeds of 350, 400, 466.67 and 560 rpm that corresponding peripheral speeds of 2.75, 3.14, 3.66 and 4.40 m/s.
- 2- Three feeding rates of 1.300, 4.100 and 6.800 Mg/h.
- 3-Three levels for rolls clearance of 1.5, 2.5 and 3.5 mm.

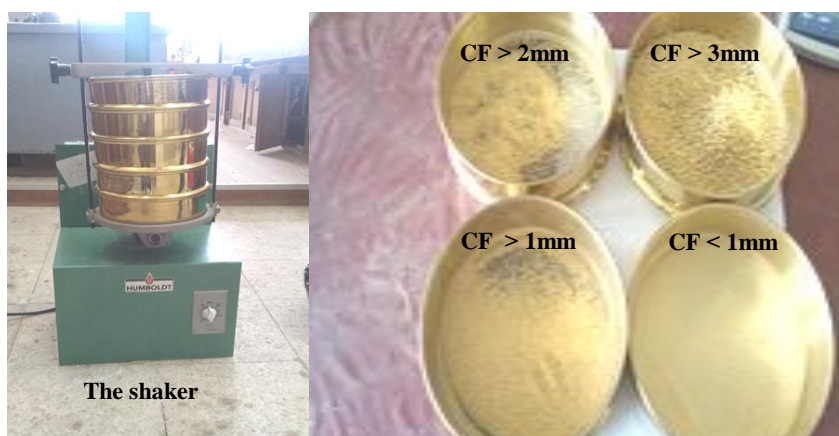

Fig.(5): The shaker and sieves.

- MEASUREMENTS:

1. Milling capacity

The actual milling capacity (Mg/h) of the machine is the actual rate of productivity by the amount of actual time consumed in operation.

2. Particle size distribution:

The recommended particle size distribution of crumbled feeds (CF) in broiler starter diet is shown in Table (2). Trials have shown that every 10% increase in fines (<1 mm) results in a reduction of 40 g body weight at 35 days, and therefore, the aim should be to minimize the amount of fine particles (<1 mm) in the crumble feed (Aviagen, 2014).

Table (2): Recommended particle size distribution of CF according to (Aviagen, 2014)

Feed form Size	Starter crumbles
>3 mm	15%
>2 mm	40%
>1 mm	35%
<1 mm	<10 %

3. Power and energy requirement:

The required milling power was calculated by using the following equation:

$$\text{Consumed Power, kW} = \frac{\sqrt{3}IV\eta \cos \theta}{1000}$$

Where:

I= line current strength in Amperes.

V = Potential strength (voltage) being equal to 390V.

$\cos \theta$ = power factor (being equal to 0.84).

η = Mechanical efficiency assumed (95%).

The specific energy requirement (kW.h/Mg) was calculated by using the following relation:

$$\text{The specific energy requirement, kW.h/Mg} = \frac{\text{The consumed power (kW)}}{\text{Actual machine capacity (Mg/h)}}$$

RESULTS AND DISCUSSION

- Roller mill capacity:

Fig. (6) describe the relation between roll speed and the actual machine capacity under different feeding rates and roll clearances. It was observed that, machine capacity increased by increasing the roll speed, roll clearance and feeding rate. Regarding relation between feeding rate and the actual machine capacity, the obtained results show that, increasing feeding rate from 1.3 to 6.8 Mg/h, the highest machine capacity at roll speed of 560 rpm(4.40 m/s) and roll clearance 3 mm was increased from 1.298 to 6.797 Mg/h whereas, the lowest machine capacity at roll speed of 350 rpm (2.75 m/s) and roll clearance 1.50 mm was increased from 0.630 to 5.713 Mg/h .This expected because the high rate of feeding could create a considerable and rapid accumulation in the clearance between the rotating rolls. Fig. (6) display that, lowest value of machine capacity recorded at roll speed of 350 rpm, feeding rate of 1.30 Mg/h and roll clearance of 1.50 mm while, he highest value of machine capacity recorded at roll speed of 560 rpm , feeding rate of 6.8 Mg/h and rolls clearance of 3.50 mm. It was noticed that, the increase of roll speed from 466.67 to 560 rpm accompanied with a very slight increase in machine capacity, especially at high feeding rates of 4.1 and 6.8 Mg/h and wide roll clearances of 2.50 and 3.50 mm.

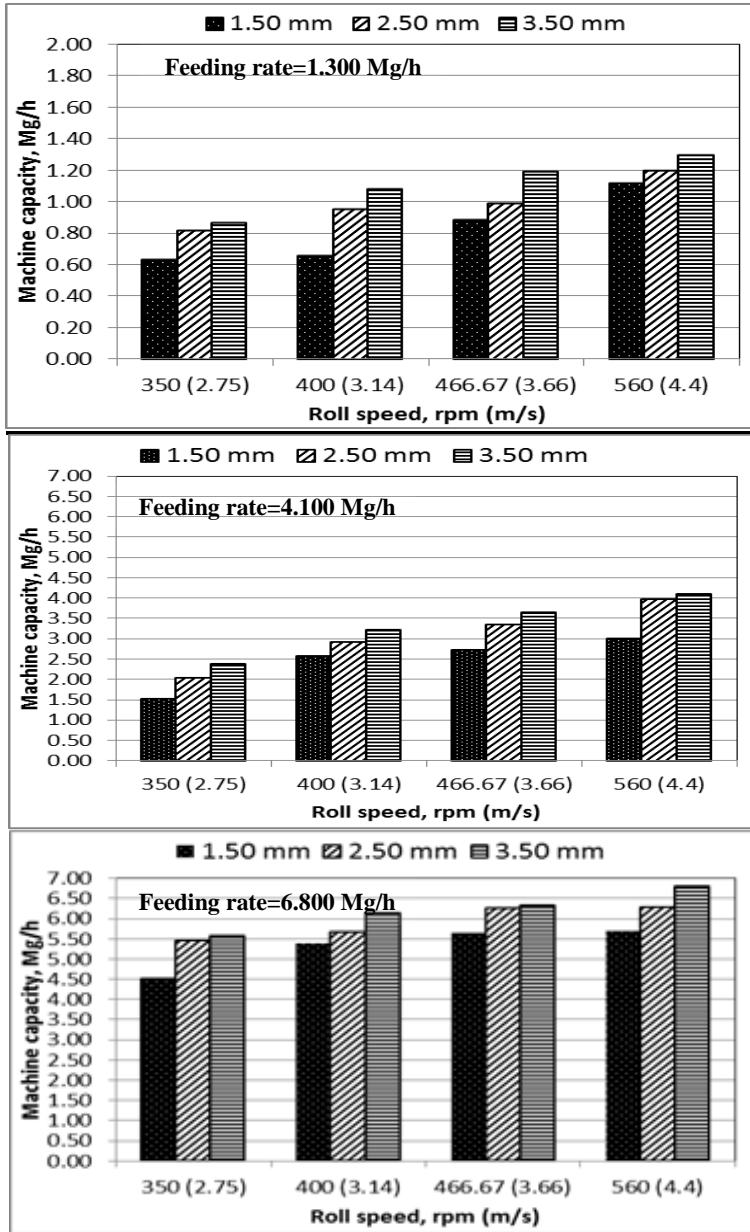

Fig.(6): Effect of rolls speed and feeding rate on the machine capacity using different roll clearances.

This can be attributed to the resistance of the huge quantity of pellet to the rotating rolls through the clearance that can lead to increase the milling time relatively and consequently reduce the capacity at the high roll speed of 560 rpm .The rolls clearance is playing an important rule to increase

the machine capacity clearly especially at high feeding rates. Hence, the highest value of machine capacity of 6.799 Mg/h was obtained at roll speed of 560 rpm (4.40 m/s) and rolls clearance of 3.5 mm, whereas the lowest value of machine capacity of 0.630 Mg/h was recorded at roll speed of 350 rpm (2.75 m/s) and roll clearance of 1.5 mm.

- Particle size distribution of the crumbled feeds (CF):

Table (3) shows the particle size distribution of the crumbled feeds (CF) using different roll speeds, feeding rates and roll clearances. It was clear that, the best crumbled feed (CF) particle size distribution has been obtained as follows: $CF < 1 \text{ mm} = 19.45\%$, $CF > 1 \text{ mm} = 29.46\%$, $CF > 2 \text{ mm} = 38.64\%$ and $CF > 3 \text{ mm} = 12.45\%$, at roll speed of 466.67 rpm (3.66 m/s), feeding rate of 6.800 Mg/h and roll clearance of 1.50 mm, as shown in Fig.(7). This distribution is very close to the particle size distribution that suit the broiler in the phase of starter that recommended by (Aviagen, 2014). Regarding the best distribution of the crumbled feeds (CF) particle size, the low roll clearance, high feeding rate and roll speed gave a relatively low percentages for both the fine ($CF < 1 \text{ mm}$) and coarse ($CF \geq 3 \text{ mm}$) particles, while the medium particles ($CF > 1 \text{ mm}$ and $CF > 2 \text{ mm}$) would increase, despite, it was expected that the small clearance would give more fines and low coarse of the CF. This can be attributed to the high accumulation of the pellets feed that occurred in the tiny roll clearance at the high feeding rate and high roll speed which leads to enlarge this clearance under the effect of the spring compression of the clearance adjustment screw, then the particle sizes of the CF will concentrate in the medium size category of the distribution.

-Energy requirement:

The relation between roll speed and specific energy requirement under different feeding rates and roll clearances is illustrated in Fig.(8). It was noticed that, the increase of roll speed, feeding rate and roll clearance would decrease the specific energy requirement for crumbling the broiler pellets. This is because the increase that occurred of machine capacity is higher than increase in power required rate, in addition to the low resistance of the pellets to the rotation of rolls during passing through the clearance at the highest values of roll speed, feeding rate and roll clearance.

Table (3): Particle size distribution of the crumbled feeds (CF) under different values of feeding rates, roll clearance and roll speeds

Feeding rate (Mg/h)	Roll clearance (mm)	Particle size distribution of the crumbled feeds (CF), %															
		CF > 3 mm				CF > 2 mm				CF < 1 mm							
		Roll speed (rpm)			350	Roll speed (rpm)			350	400	466.67	560	Roll speed (rpm)			350	400
1.3	1.50	19.17	6.85	18.89	9.61	29.47	23.51	33.00	20.20	36.24	45.96	30.28	42.43	20.17	23.68	17.83	27.76
	2.50	16.43	17.76	20.59	20.78	33.80	29.49	29.82	27.92	31.08	33.06	32.01	31.07	18.69	19.69	17.58	20.23
	3.50	21.93	25.08	33.63	36.21	43.06	26.17	30.14	13.59	20.62	28.52	22.65	28.27	14.39	20.23	13.58	21.93
4.1	1.50	0.55	9.23	17.53	12.03	30.91	30.80	39.00	16.32	41.64	37.50	25.68	40.20	26.90	22.47	16.89	31.45
	2.50	21.20	30.01	18.65	23.51	27.50	33.00	38.28	24.92	30.67	24.73	22.66	30.85	20.63	12.26	20.41	20.72
	3.50	25.21	77.00	45.82	47.83	29.66	30.12	26.90	15.21	26.62	24.40	18.71	24.16	18.51	18.71	8.57	12.80
6.8	1.50	18.00	5.08	12.45	20.50	24.47	30.00	38.64	16.56	31.22	39.67	29.46	35.30	21.31	25.25	19.45	27.64
	2.50	25.02	38.07	25.08	37.57	33.32	28.77	28.65	18.42	25.86	23.00	26.53	25.64	15.80	10.16	19.74	18.37
	3.50	31.84	37.48	51.80	53.68	28.24	26.78	23.47	12.14	25.03	20.65	18.39	23.98	14.89	15.09	6.34	10.20

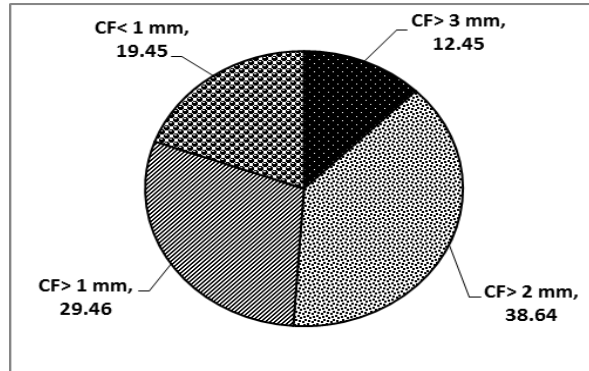

Fig.(7): The best distribution of the CF particle size for the starter.

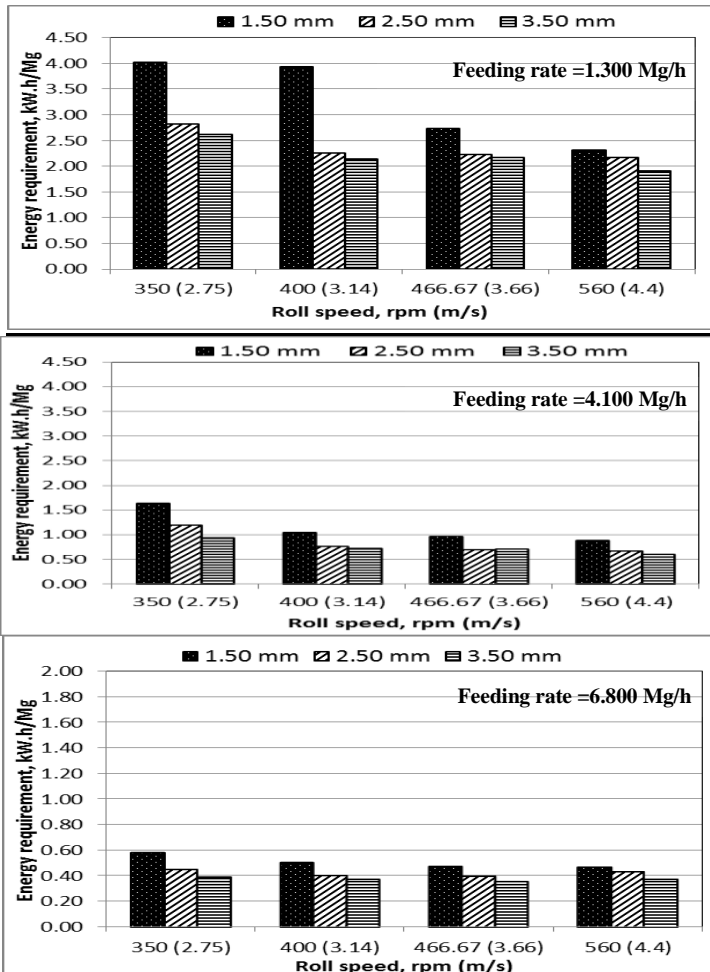

Fig.(8): Effect of rolls speed and feeding rate on the energy requirement under different roll clearances

Generally, the lowest value of specific energy requirement of 0.380 kW.h/Mg was obtained at roll speed of 560 rpm (4.40 m/s), feeding rate of 6.80 Mg/h and roll clearance of 3.50 mm, while the highest value of specific energy requirement of 4.020 kW.h/Mg was obtained at roll speed of 350 rpm (2.75 m/s), feeding rate of 1.300 Mg/h and roll clearance of 1.50 mm. From previous discussion, it was found that, the corresponding energy requirement to the best CF particle size distribution (as displayed in Fig.7) of 0.476 kW.h/Mg was recorded at roll speed of 466.67 rpm (3.66 m/s), feeding rate of 6.80 Mg/h and roll clearance of 1.50 mm at machine capacity of 5.650 Mg/h.

CONCLUSION

From this investigation, the obtained results revealed that, the proper conditions for operating the roller mill that used to produce crumbled feeds (CF) from poultry pellets were the roll speed of 466.67 rpm (3.66 m/s), feeding rate of 6.800 Mg/h and roll clearance of 1.50 mm to achieve the best CF particle size distribution of (<1 mm= 19.45%, ≥1 mm= 29.46%, ≥2mm= 38.64% and ≥3 mm=12.45 %) that suit the broiler in the phase of starter as recommended by (**Aviagen,2014**) at machine capacity of 5.650 Mg/h and consumed energy of about 0.476 kW.h/Mg.

REFERENCES

- Aviagen (2014)** ROSS Broiler Management Handbook: Provision Feed and Water, 30 pp.
- Banerjee, G.C. (1998)** Poultry. Third edition, Oxford and IBH Publishing Co. Pvt. Ltd., Calcutta, India, 120-121 pp.
- Behnke, K.C. (1994)** Factors Affecting Pellet Quality. Maryland Nutrition Conference, Department of Poultry Science and Animal Science, University of Maryland, College Park, Madison, USA.
- Behnke, K.C. (1998)** Why pellet? in Proceeding. of Kansas State University /Amer. Feed Industry Association Pellet Conference, Manhattan, Kansas, USA.
- Dozier, W.A. (2002)** Reducing utility cost in the feed mill. Watt Poultry USA, 53:40-44 pp.
- Jahan, M. S.; M. Asaduzzaman and A.K. Sarkar (2006)** Performance of broiler fed on mash, pellet and crumble. International Journal of Poultry Science, 5 (3): 265-270 pp.

- Mohamed, E.A. and E.A. Talha (2012)** The effect of feeding pellets versus mash on performance and carcass characteristics of broiler chicks. Bull. Env. Pharmacol. Life Sci. Vol: 2 (2), www.bepsls.com
- Nir, I. and I. Ptichi (2001)** Feed particle size and hardness: Influence on performance, nutritional, behavioral and metabolic aspects. In: Proceedings of the 1st World Feed Conference, Utrecht, the Netherlands, 157-186 pp.
- Nir, I.; R. Hillel; I. Ptichi and G. Shefet (1995)** Effect of particle size on performance. 3: Grinding pelleting interactions. Poultry Science, 74: 771-783 pp.
- Waldroup, P.W. (1997)** Particle size reduction of cereal grains and its significance in poultry nutrition. Technical Bulletin, American Soybean Association, Sinclearanceore, 14 pp.

الملخص العربي

تقييم أداء آلة جرش لإنتاج أعلاف دواجن التسمين المحببة

حنان محمد سعد الدين الشال*

الهدف من هذه الدراسة هو تقييم بعض العوامل التشغيلية المؤثرة علي أداء آلة جرش أعلاف الدواجن المصبغة ذات الأسطوانات، وعلي توزيع أحجام الحبيبات أثناء إنتاج الأعلاف المحببة واللازمة لدواجن التسمين في مرحلة الكتاكيت البادئة. تم تصنيع أصبغيات العلف من تركيبة علفية تشمل المكونات والنسب الموصي بها لمرحلة كتاكيت التسمين البادئة. تم تقييم أداء الآلة بإستخدام متغيرات للتشغيل تشمل أربع سرعات دورانية لإسطوانات الجرش و هي ٣٥٠، ٤٠٠، ٤٦٦، ٦٧ لفة/دقيقة و التي تناظر سرعات محيطية ٢،٧٥، ٣،١٤، ٣،٦٦، ٤،٤٠ م/ث وثلاث قيم لخلوص الإسطوانات ١،٥٠، ٢،٥٠، ٣،٥٠ مم وأربع معدلات للتغذية هي ١،٣، ١،٤، ٦،٨ ميجا جرام/ساعة مع الأخذ في الاعتبار حساب كل من السعة الإنتاجية للآلة، توزيع أحجام الحبيبات، والطاقة المستهلكة. حيث توصي النتائج المتحصل عليها بإستخدام آلة جرش أعلاف الدواجن المصبغة لأنتاج أعلاف محببة عند سرعة دورانية لأسطوانات الجرش مقدارها ٤٦٦، ٦٧ لفة/دقيقة (٣، ٦٦ م/ث) ومعدل تغذية ٥، ٦٥٠ ميجا جرام/ ساعة وخلوص ١، ٥٠ مم بين أسطوانتي الجرش لتحقيق أفضل توزيع لأحجام الحبيبات و الذي يتمثل في $\langle \text{مم} = ١٩,٤٥ \%$ ، $\langle \text{مم} = ٢٩,٤٦ \%$ ، $\langle \text{مم} = ٣٨,٦٤ \%$ ، $\langle \text{مم} = ١٢,٤٥ \%$ و التي تناسب دواجن التسمين في مرحلة الكتاكيت البادئة وذلك عند سعة إنتاجية للآلة مقدارها ٥، ٦٥٠ ميجا جرام/ساعة و طاقة مستهلكة حوالي ٠، ٤٧٦ كيلوات. ساعة/ميجا جرام.

* مدرس الهندسة الزراعية – كلية الزراعة – جامعة الزقازيق- مصر.