

## UTILIZATION OF EFFLUENT FISH FARMS IN LETTUCE PRODUCTION

Amira A. M. Amin<sup>1</sup>, El-Sayed G. Khater<sup>2&\*</sup>, Samir A. Ali<sup>3</sup> and Salah M. Kamal<sup>4</sup>

<sup>1</sup> PhD Stud., Ag. Eng. Dept., Fac. of Ag., Benha U., Egypt.

<sup>2</sup> Assoc. Prof., Ag. Eng. Dept., Fac. of Ag., Benha U., Egypt.

<sup>3</sup> Prof., Ag. Eng. Dept., Fac. of Ag., Benha U., Egypt.

<sup>4</sup> Prof. and Deputy Director of Central Laboratory for Aquaculture Res., Egypt.

\*E-mail: [alsayed.khater@fagr.bu.edu.eg](mailto:alsayed.khater@fagr.bu.edu.eg)

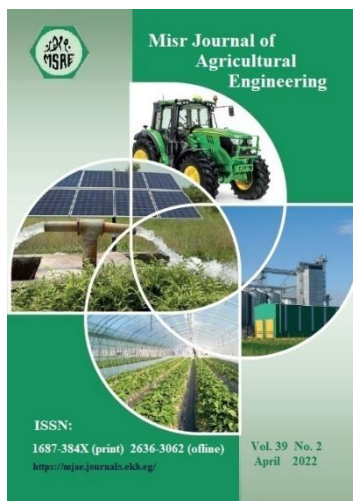

© Misr J. Ag. Eng. (MJAE)

### Keywords:

Aquaponic; Aquaculture;  
Hydroponic; Fish; Lettuce  
plant; Root; Shoot; Weight  
gain.

### ABSTRACT

*The main aim of this work is to investigate to which extent the content of nutrients in water discharged from fish farms is sufficient for growing lettuce plants, in order to reduce the using of chemical fertilizers, save water, improve the plant and fish. To achieve that study the effect of different flow rate (1.0, 1.5 and 2.0 L h<sup>-1</sup>) and culture system (A shape, gutter and deep water) on root length, fresh and dry weight of shoot and root and nutrients uptake for lettuce plants in hydroponic and aquaponic systems. The obtained results indicated that the highest value of the length of root (26.93 cm) was found with waste fish farm for deep water hydroponic system. The fresh and dry of shoot and root for lettuce plants grown in gutter hydroponic system was better than those grown in different culture system with 1.5 L h<sup>-1</sup> plant<sup>-1</sup> flow rate. The highest values of N, P, K, Ca and Mg uptake were 2.86, 0.85, 3.20, 1.90 and 0.30 %, respectively, for all treatments. The total weight gain, fish growth rate and specific growth rate were 138.9 g, 2.78 g day<sup>-1</sup> and 2.03 %, respectively.*

### 1. INTRODUCTION

**A**quaponics is an integrated farming concept that combines fish, hydroponic plant production, and nitrifying bacteria in a symbiotic environment. The most common form is the integration of hydroponic beds in the water circuit of a recirculating aquaculture system (RAS) (Delaide et al., 2015 and Rakocy, 2012). This integration aims to convert the normally wasted nutrients excreted by fish into valuable plant biomass. This allows for lower water exchange and spillage which should significantly reduce the environmental impact of fish and hydroponic plant production.

Aquaponics can be considered as an emerging approach that combines intensive production with waste recycling and water conservation (Klinger and Naylor, 2012). It is an integration of hydroponic plant production in a RAS which utilizes the nutrient-rich wastewater as an input for plant growth. Aquaponics reduces the cost of artificial nutrient supplementation needed in a hydroponics system and it also benefits the RAS by reducing the cost of water treatment. Thus, aquaponics can rear fish in high stocking densities and bear low cost than the

sophisticated RASs. Nutrient removal and water reuse ability in aquaponics vary depending on the hydroponic medium, hydraulic loading rate, plant species, and the plant: fish ratio (**Lennard and Leonard, 2006 and Graber and Junge, 2009**).

Aquaponic system is one of the economical solutions for getting benefits from the water-waste from the fish farms as it save nutrients and produce fresh vegetables. With using this system successively its cost will be decreased and became more economic. The produced plants via this system considered as an organic product which is more safe for human consumption (**Khater and Ali, 2015 and Khater et al., 2015**).

Fish production in ponds fertilized with excreta is a very ancient practice, and wastewater had been used for the aquaculture production in different countries (**Hoan and Edwards, 2005**). Also, in the agricultural sector; treated, diluted, untreated, or partly treated wastewater has been used for irrigation (**Ensink et al., 2004 and Keraita and Drechsel, 2004**). There are additional concerns about food safety and consumer acceptance of aquaponic production because there is increased risk of cross-contamination including the spread of *Salmonella* and *Escherichia coli* in fish production (**Hollyer et al., 2009**). Although there are little drawbacks with the system, if remediated water is applied to aquaponic systems, it would be economically beneficial, cost-effective, and provide extra advantages. The remediated water would be an extra supplementation of the nutrients and decomposers to the aquaponics. Thus, it will ultimately reduce the establishment time period of the hydroponic component in the aquaponics as well as reduce the cost of introducing decomposers to the system.

Three types of beds are most frequently used in aquaponics: nutrient film technique (NFT); ebb-and-flow (EAF); and deep water culture (DWC or RAFT) beds. EAF beds composed of heavy substrate (e.g; clay balls, perlite, etc) and siphon bells seem to be less practical for maintenance (**Rakocy and Hargreaves, 1993**) and there is only a few reports on their production performance compared to DWC or NFT (**Lennard and Leonard, 2006**). Aquaponics is a new research field and a theoretical lower environmental footprint compared to conventional farming methods is expected but there is a lack of data establishing it. Namely, the water and energy used but also the expectable plant yields are not yet well documented and need to be compared to RAS and hydroponic systems. The ability of aquaponic systems to produce the same yield and quality as conventional one need to be also reported.

Small proportion of ammonia is toxic to fish, when as nitrate is not toxic to fish. If nitrate increased over a specific limit it will be toxic to fish eaters (human being) and cause nitrate pollution and the eaters will suffer from methamoglobinemia disease. The blood of the affected people became brown and will not be able to carry oxygen to the rest of human organs (**Tucker and Boyed, 1985**). To avoid this problem in aquaculture, part of water should be discharged daily and add fresh water instead. Another solution to this problem is establishing hydroponic system attached to the aquaculture and cultivates plants in the hydroponics in order to save discharged-water and gets use of existing nitrate. Therefore, the main aim of this work is to investigate to which extent the content of nutrients in water discharged from fish farms is sufficient for growing lettuce plants, in order to reduce the using of chemical fertilizers, save water, improve the plant and fish.

## **2. MATERIALS AND METHODS**

The main experiment was carried out in a greenhouse at Fish Farms and Protected Houses Center, Faculty of Agriculture Moshtohor, Benha University, Egypt (latitude 30° 21` N and 31° 13` E). During the period of November and December, 2020 season.

### **2.1. Materials**

#### **2.1.1. System Description**

Fig. 1 illustrates the experimental setup. It shows the system which consists of fish tanks, screen filter, biological filter, oxygen generator, oxygen mixer, hydroponic units, pumps and pipelines made of polyvinyl chloride were installed to connect components of system to recirculate the water.

##### **2.1.1.1. Fish farm**

Four fish tanks are an octagonal in shape and made from concrete has to openings for both settleable and suspended solids. The water volume used in each tank is 150 m<sup>3</sup> and has a height of 2.0 m. Each tank is provided with a particle trap in the center for water drain waste solids. The first opening allows for 1-15% of the total flow, the second opening allows for 85 – 99% of the total flow.

Two drum screen filters used in this system which has dimensions of 1.20 m in diameter and 2.0 m long. The filter was made from stainless steel at private company for steel industry. The fine mesh silk 60 micron was used a media of screening. The filter was driven by one motor of 1.0 kW power and 1500 rpm and a gearbox was used to reduce the rotation speed 500 times to give the recommended rotating speed (3 rpm).

Trickling biological filter used in this system, has 8.0 m in long, 4.0 m width and 4.0 m high. The filter was made from concrete. Used plastic sheets were used as a media. The total volume of media used in this system is 96 m<sup>3</sup>.

Pure oxygen used in this system source of oxygen gas was oxygen generator. Adding pure oxygen gas to water by oxygen mixer. The water and oxygen enter the top of the oxygen mixer, as the water and oxygen move downward. Oxygen generator is used to provide the oxygenation system with its requirements of pure oxygen- It consists of air compressor (Model BOGE – Flow rate 15 m<sup>3</sup> h<sup>-1</sup> – Head 10 bar – Power 25 kW, Germany), Refrigeration unit, Filtration unit, 1 m<sup>3</sup> stainless steel tank for storage air, oxygen generator (Model BOGE – Flow rate 10.75 m<sup>3</sup> h<sup>-1</sup> – Head 6.25 bar – power 1 kW, Germany) and 1 m<sup>3</sup> stainless steel tank for storage oxygen pure.

##### **2.1.1.2. Hydroponic systems**

Hydroponic systems consist of three types of hydroponic systems (deep water, A shape and gutter systems).

The deep water system consists of six rectangular concrete tanks covered by polyethylene sheet with 1 mm thickness that used for lettuce plants culture. Dimensions of each tank are 17.5 m long, 1.2 m wide and 0.3 m high. The ground slope of tanks was 2 %. The tanks were covered with foam boards to support the plants. Fig. 2 shows the deep water system.

The two A shape system consists of three stands made of iron. Dimensions of each stand are 1.2 m wide and 1.7 m high. Each A shape consists nine polyvinyl chloride (PVC) pipe, the dimensions of pipe are 110 mm in diameter and 6.0 m long. The slope of pipes was 2 %. Small tubes (16 mm) were used to provide tanks with solution in a closed system. Fig. 3 shows the A shape system.

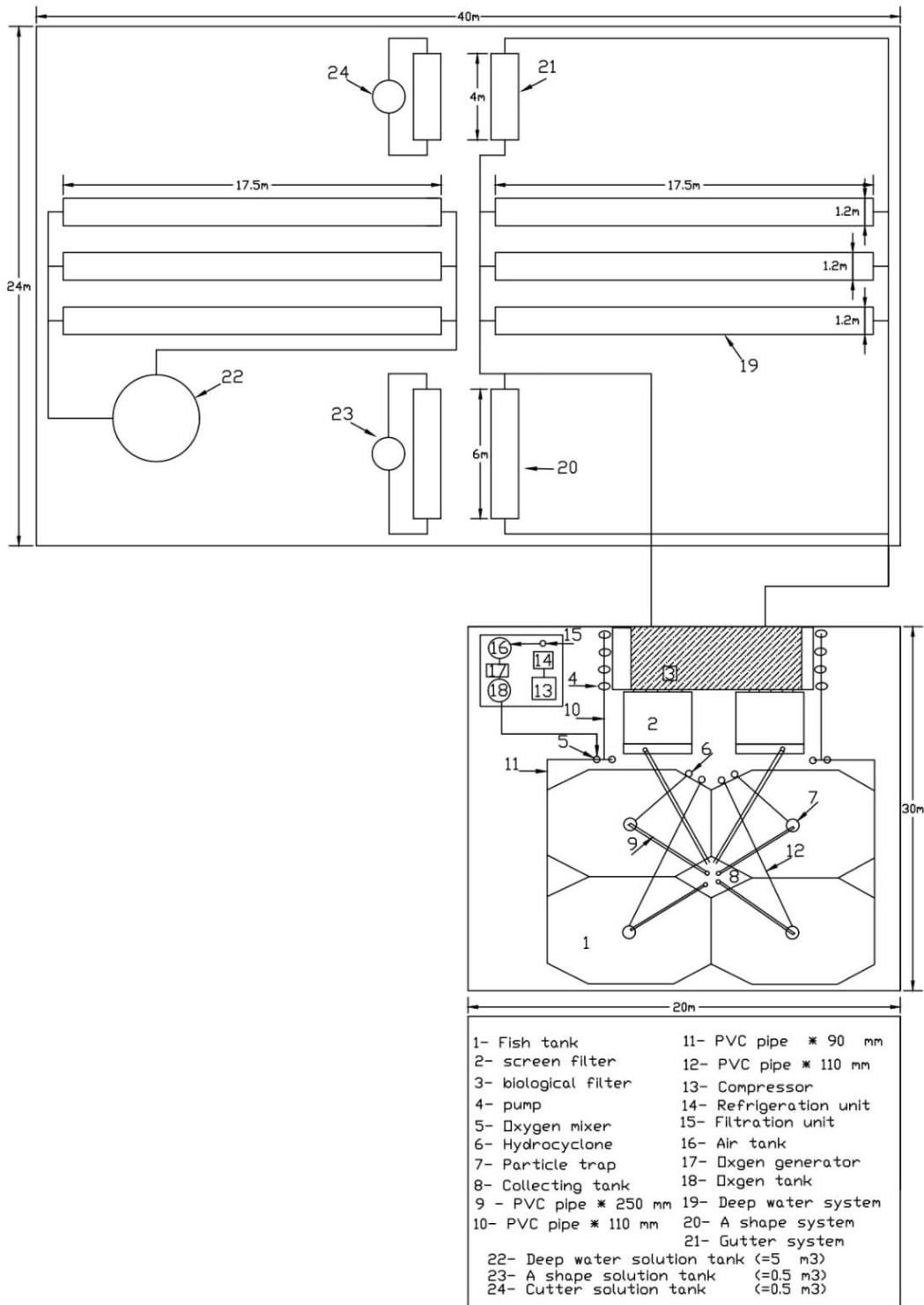

Fig. 1: The experimental setup

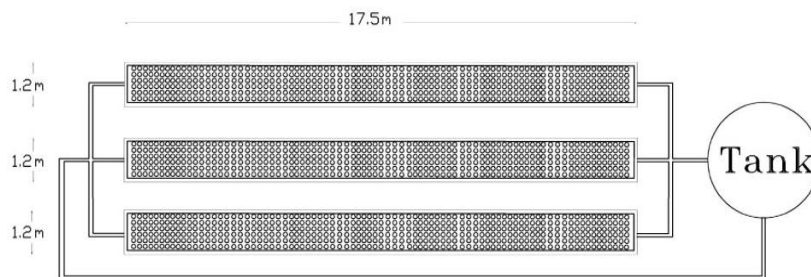

Fig. 2: The deep water system

The two gutter system consists of three stands made of iron. Dimensions of each stand are 1.2 m wide and 1.0 m high. Each gutter system consists three gutters made of PVC. The dimensions of each gutter are 4.0 m long, 0.15 m wide and 0.10 m high. The slope of gutters was 2 %. Small tubes (16 mm) were used to provide tanks with solution in a closed system. Fig. 4 shows the gutter system.

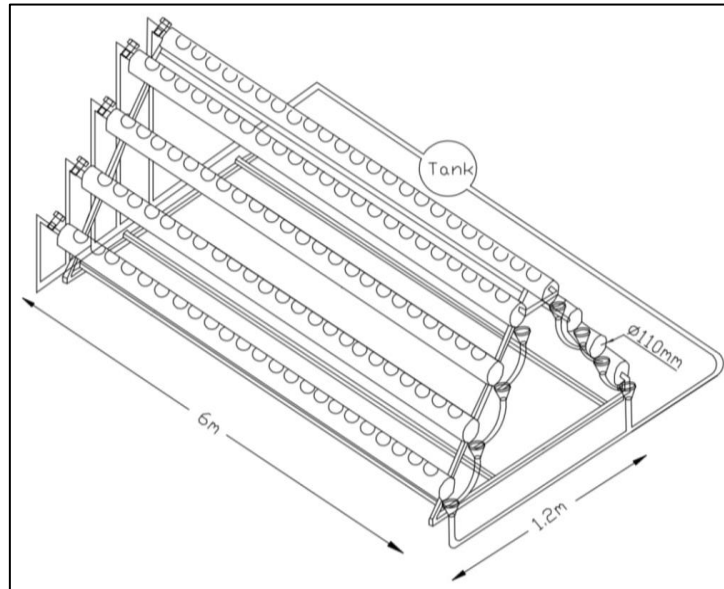

Fig. 3: A shape system.

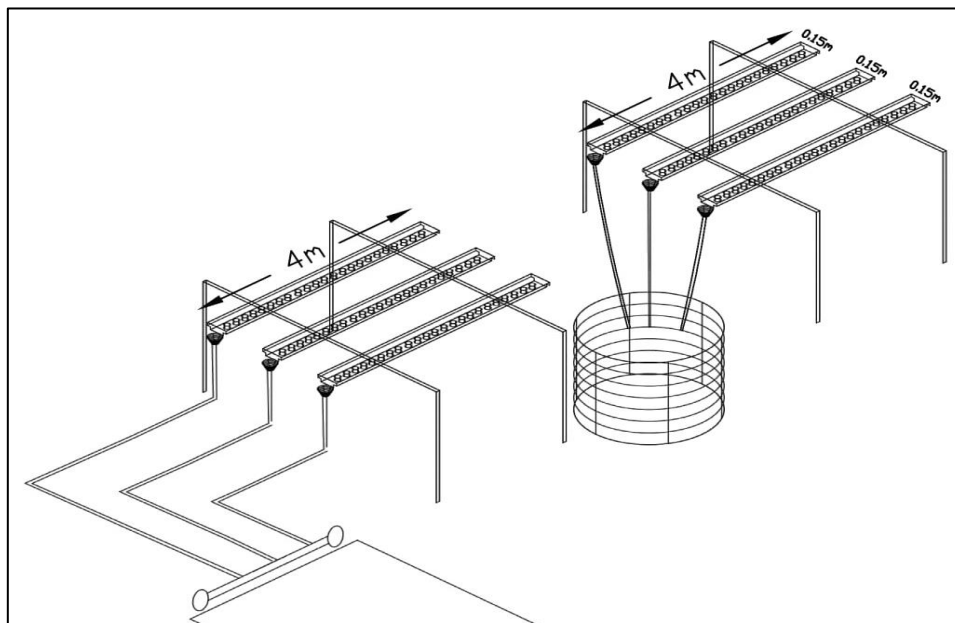

Fig. 4: Gutter system

The circular polyethylene tank of the nutrient solution system was used for collecting the drained solution by gravity from the ends of the three systems. The nutrient solutions were prepared manually according to (Khater, 2006) by dissolving appropriate amounts of  $\text{Ca}(\text{NO}_3)_2$ ,  $236 \text{ g L}^{-1}$ ,  $\text{KNO}_3$ ,  $101 \text{ g L}^{-1}$ ,  $\text{K}_2\text{SO}_4$ ,  $115 \text{ g L}^{-1}$ ,  $\text{KH}_2\text{PO}_4$ ,  $136 \text{ g L}^{-1}$ ,  $\text{MgSO}_4$ ,  $246 \text{ g L}^{-1}$  and chelates for trace elements into preacidified groundwater (from the following ppm concentration are achieved in this formulation:  $\text{N} = 210$ ,  $\text{P} = 31$ ,  $\text{K} = 234$ ,  $\text{Ca} = 200$ ,  $\text{Mg} = 48$ ,  $\text{S} = 64$ ,  $\text{Fe} = 14$ ,  $\text{Mn} = 0.5$ ,  $\text{Zn} = 0.05$ ,  $\text{Cu} = 0.02$ ,  $\text{B} = 0.5$ ,  $\text{Mo} = 0.01$ ). pH and Electrical

Conductivity (EC) were further adjusted to 6.5–7.0 and 800 – 840 ppm, respectively, after salt addition. The average air ambient temperature was  $25.97 \pm 4.37$  °C and the average water temperature was  $24.03 \pm 3.92$  °C. The average relative humidity was 65.4% and the light intensity was  $338.55 \pm 40.06$  W m<sup>-2</sup>.

### 2.1.2. Plant and fish species

#### 2.1.2.1. Lettuce plants

Lettuce seedlings were grown in the plastic cups (7 cm diameter and 7 cm height) filled with peat moss. The cups were irrigated daily using water with nutrient solution. Two weeks old lettuce seedlings were planted at 25.0 plant m<sup>-2</sup> in the experimental tanks (**Khater and Ali, 2015**).

#### 2.1.2.2. Nile Tilapia fish

Tilapia nilotica fingerlings (an individual weight of 79.23 g), which were used in the beginning of experiment. The fish was weighed every ten days and the flow rate was adjusted according to the growth rate. The daily feed rates at different fish sizes were applied according to **Rakocy (1989)** and the feed pellet diameter was prepared according to **Jauncey and Ross (1982)**. Feeding was stopped during weighing process.

## 2.2. Methods

### 2.2.1. Treatments

The treatments were arranged in a split-split plot design in three replications. The treatments include: two nutrients sources (effluent fish farm and stock nutrient solution), three systems of hydroponics (deep water, A shape and gutter systems) and three flow rates are 1.0, 1.5 and 2.0 L h<sup>-1</sup> per plant.

### 2.2.2. Measurements

#### 2.2.2.1. Plant samples

Root length was measured every ten days. To study the behavior of root growth, their mass production and assess to which extent their roots could be grown in the growing solution.

The fresh and dry weight of shoot and root were measured at the end of the experiment. Dry weight the plants were measured by using oven dryer at 65 °C until constant weight was reached.

Total content of macro elements were evaluated after being digested according to **Chapman and Partt (1961)**. Nitrogen was determined by Kjeldahl digestion apparatus (**Bremmer and Mulvaney, 1982**). Potassium, Calcium and magnesium were determined by Photofatometer (Model Jenway PFP7 – Range 0 - 160 mmol L<sup>-1</sup>, USA) and phosphorus (P) was determined colorimetrically following the **Murphy and Riley (1962)** method.

#### 2.2.2.2. Biological factors of fish

Fish sample were taken every ten days to determine the biological parameters which include: weight gain, fish growth rate, specific growth rate, feed conversion ratio and feed efficiency ratio using the following equations according to (**Khater, 2012**):

$$WG = W_f - W_i \quad (1)$$

$$FGR = \frac{WG}{t} \quad (2)$$

$$SGR = \frac{\ln W_f - \ln W_i}{t} \times 100 \quad (3)$$

$$FCR = \frac{FI}{WG.n_t} \quad (4)$$

$$FER = \frac{WG.n_t}{FI} \quad (5)$$

Where:

WG is the mass gained, g

$W_f$  is the mean final fish mass, g

$W_i$  is the mean initial fish mass, g

FGR is the fish growth rate, g day<sup>-1</sup>

SGR is the specific growth rate, (% or g day<sup>-1</sup>)

t is the time, day

FCR is the feed conversion ratio, g feed g<sup>-1</sup> fish

FER is the feed Efficiency ratio, g fish g<sup>-1</sup> feed

FI is the feed intake, g

$n_t$  is the final number of fish in the tank

### **3. RESULTS AND DISCUSSION**

#### **3.1. Plant growth parameters**

##### **3.1.1. Root length**

Figs. 5a, b and c show the root length of lettuce plants grown during the growth period in source of nutrients (stock nutrient solution and effluent fish farm), different hydroponic systems (A shape, Gutter and Deep water systems) and different flow rates (1.0, 1.5 and 2.0 L h<sup>-1</sup> plant<sup>-1</sup>). The results indicate that the root of the lettuce plant grown in different culture system increases with increasing flow rate and plant age. It could be seen that the root length of lettuce plants increased from 3.95 to 23.75, 3.78 to 25.13 and 3.85 to 24.78 and 4.88 to 24.38, 4.85 to 25.55 and 4.83 to 23.15 cm, when the lettuce plant age increased from 10 to 50 days, respectively, at 1.0, 1.5 and 2.0 L h<sup>-1</sup> plant<sup>-1</sup> in nutrients solution and water discharged of the fish farm, respectively, for A shape hydroponic system.

For gutter hydroponic system, the root length of lettuce plants increased from 4.48 to 24.93, 4.58 to 25.43 and 4.30 to 24.58 and 4.83 to 25.38, 4.95 to 26.10 and 5.00 to 25.75 cm, when the lettuce plant age increased from 10 to 50 days, respectively, at 1.0, 1.5 and 2.0 L h<sup>-1</sup> plant<sup>-1</sup> in nutrients solution and water discharged of the fish farm, respectively. For deep water hydroponic system, the root length of lettuce plants increased from 5.65 to 25.10, 5.53 to 25.30 and 5.28 to 25.53 and 5.88 to 26.38, 5.85 to 26.93 and 5.85 to 25.33 cm, when the lettuce plant age increased from 10 to 50 days, respectively, at 1.0, 1.5 and 2.0 L h<sup>-1</sup> plant<sup>-1</sup> in nutrients solution and water discharged of the fish farm, respectively. It was noticed that there was not any overlapping (interference) between roots of the growing plants as a result of choosing a suitable distance (25 cm) apart between plants during different growth stages. If there is any overlapping existed it was very limited. These results were in agreement with **Khater and Ali (2015) and Khater (2016)** found that the plant spacing for lettuce was (20-25 cm).

The highest value of the length of root (26.93 cm) was found with waste fish farm for deep water hydroponic system. However, the lowest value of the length of root was found to be 23.75 cm with nutrient solution for A shape hydroponic system.

Regarding the flow rate, the results indicate that the average root length of lettuce plants increased from 4.95 to 24.99, 4.92 to 25.74 and 4.85 to 24.85 cm, when the lettuce plant age increased from 10 to 50 days, respectively, at 1.0, 1.5 and 2.0 L h<sup>-1</sup> plant<sup>-1</sup> for all treatments.

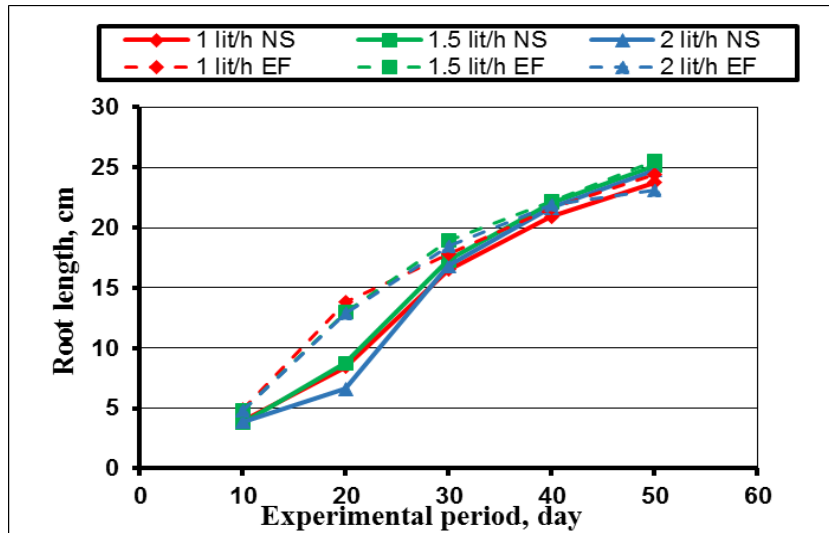

Fig. 5a: The root length of lettuce plants grown A shape system.

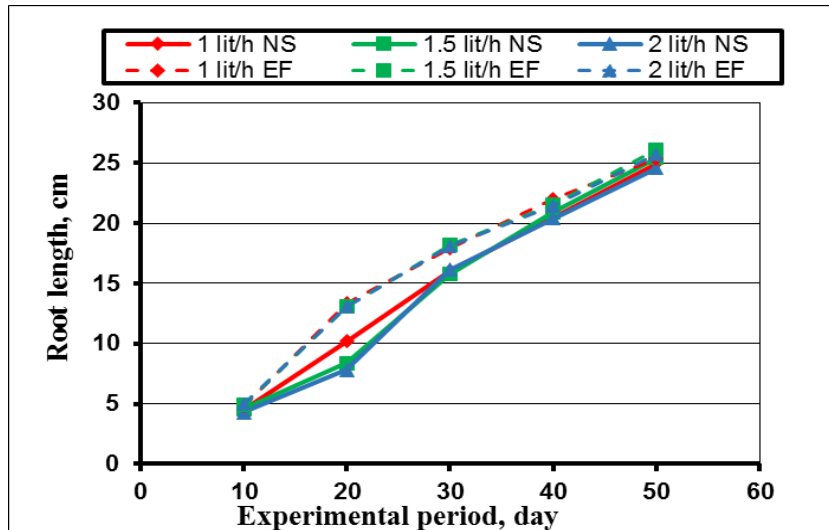

Fig. 5b: The root length of lettuce plants grown gutter system.

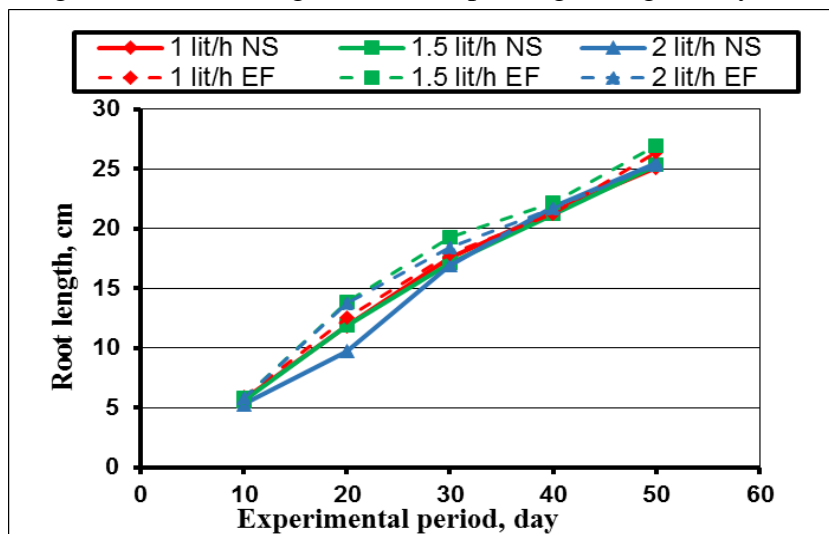

Fig. 5c: The root length of lettuce plants grown deep water system.



Regarding the hydroponic systems, the results indicate that the average root length of lettuce plants increased from 4.36 to 24.45, 4.69 to 25.36 and 5.67 to 25.76 cm, when the lettuce plant age increased from 10 to 50 days, respectively, A shape, gutter and deep water systems for all treatments.

Multiple regression analysis was carried out to obtain a relationship between the root length of lettuce plants as dependent variable and different both of culture system, flow rate (1.0, 1.5 and 2.0 L h<sup>-1</sup>) and experimental period (1 to 50 days) as independent variables. The best fit for this relationship is presented in the following equation:

$$RL = a + bT + cQ \tag{6}$$

Where:

RL is the root length of lettuce plant, cm

T is the lettuce plant age, day

Q is the flow rate, L h<sup>-1</sup>

The constants of these equation and coefficient of determination are listed in Table 1.

Table 1: The constants a, b, c and coefficient of determination for root length.

Hydroponic System	Nutrients Source	Constant			R <sup>2</sup>
		a	b	c	
A Shape	NS	-1.64	0.55	0.06	0.96
	EFF	2.62	0.48	-0.25	0.93
Gutter	NS	-0.21	0.53	-0.59	0.98
	EFF	1.62	0.50	-0.002	0.96
Deep Water	NS	1.82	0.50	-0.47	0.98
	EFF	2.09	0.49	0.23	0.97

NS: nutrient solution - EFF: effluent fish farm

### 3.2. Fresh and dry weight of shoot and root

#### 3.2.1. Fresh and dry weight of shoot

Figs. 6a and b show fresh and dry weight of shoot of lettuce plants grown in different source of nutrients (stock nutrient solution and effluent fish farm), different hydroponic systems (A shape, Gutter and Deep water systems) and different flow rates (1.0, 1.5 and 2.0 L h<sup>-1</sup> plant<sup>-1</sup>) at the end of experimental period. The results indicate that the fresh weight of shoot of lettuce plants values 206.71, 297.38 and 212.30 and 190.27, 236.81 and 182.53 g plant<sup>-1</sup> for 1.0, 1.5 and 2.0 L h<sup>-1</sup> plant<sup>-1</sup>, respectively, in nutrients solution and water discharged of the fish farm, respectively, for A shape hydroponic system. For gutter hydroponic system, the fresh weight of shoot of lettuce plants values were 238.37, 315.82 and 254.22 and 223.80, 286.13 and 201.90 g plant<sup>-1</sup> for 1.0, 1.5 and 2.0 L h<sup>-1</sup> plant<sup>-1</sup>, respectively, in nutrients solution and water discharged of the fish farm, respectively. While, the fresh weight of shoot of lettuce plants values were 189.37, 250.19 and 191.62 and 177.80, 215.42 and 176.33 g plant<sup>-1</sup> for 1.0, 1.5 and 2.0 L h<sup>-1</sup> plant<sup>-1</sup>, respectively, in nutrients solution and water discharged of the fish farm, respectively, for deep water hydroponic system. This helps explain yield and growth of lettuce plants differences from various solutions. Generally, the growth of lettuce plant in a solution has optimum conditions depending on the amount of nutrients available to the plants and their balance in addition to sufficient, oxygen supply, the appropriate osmotic pressure of solution and its temperature. These results were in agreement with (Maucieri *et al.*, 2019 and Khater *et al.*, 2021).

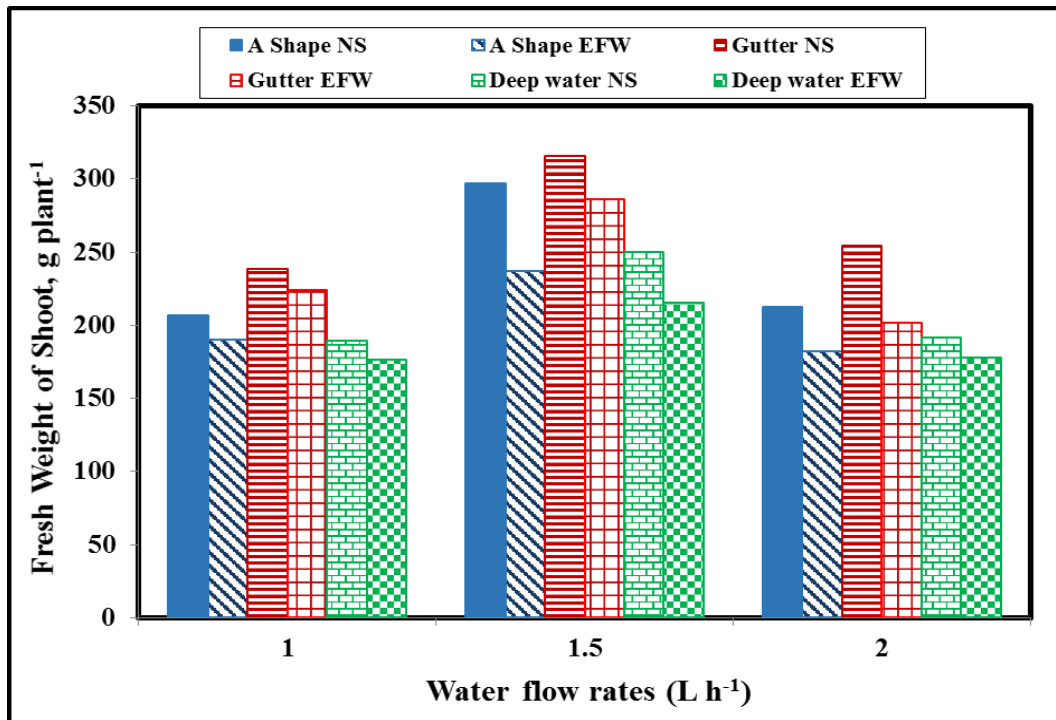

Fig. 6a: The fresh weight of shoot of lettuce plants.

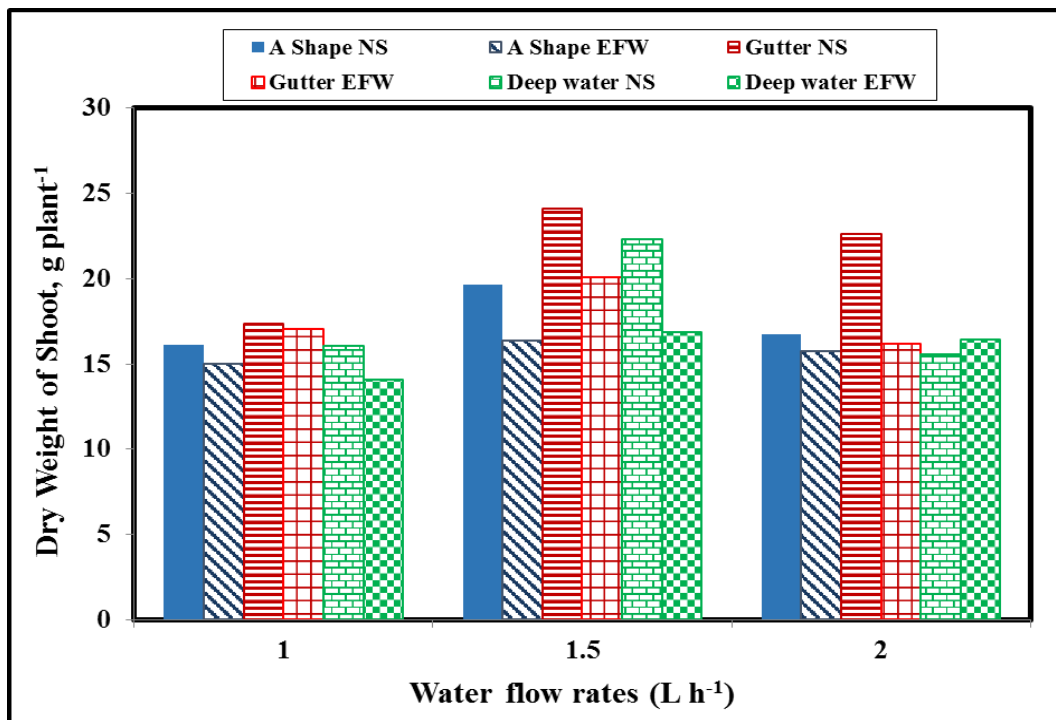

Fig. 6b: The dry weight of shoot of lettuce plants.

The results also indicate that the dry weight of shoot of lettuce plants values 14.08, 19.62 and 16.77 and 15.03, 16.37 and 15.72 g plant<sup>-1</sup> for 1.0, 1.5 and 2.0 L h<sup>-1</sup> plant<sup>-1</sup>, respectively, in nutrients solution and water discharged of the fish farm, respectively, for A shape hydroponic system. For gutter hydroponic system, the dry weight of shoot of lettuce plants values were 17.33, 24.09 and 22.63 and 17.05, 20.07 and 16.20 g plant<sup>-1</sup> for 1.0, 1.5 and 2.0 L h<sup>-1</sup> plant<sup>-1</sup>, respectively, in nutrients solution and water discharged of the fish farm, respectively. While, the dry weight of shoot of lettuce plants values were 16.08, 22.30 and 15.57 and 16.10, 16.89

and 16.44 g plant<sup>-1</sup> for 1.0, 1.5 and 2.0 L h<sup>-1</sup> plant<sup>-1</sup>, respectively, in nutrients solution and water discharged of the fish farm, respectively, for deep water hydroponic system.

The results indicate that the highest values of fresh and dry weight of shoot (315.82 and 24.09 g plant<sup>-1</sup>) were found with gutter hydroponic system and 1.5 L h<sup>-1</sup> plant<sup>-1</sup> of flow rate, while, the lowest values of fresh and dry weight of shoot (176.33 and 14.08 g plant<sup>-1</sup>) were found with deep water hydroponic system and 1.0 L h<sup>-1</sup> plant<sup>-1</sup> of flow rate. These results agreed with those obtained by **Khater (2006)**, **Genuncio *et al.* (2012)** and **Hussain *et al.* (2014)** whose found that the highest values of fresh and dry weight of plant were found with a flow rate of 1.5 L h<sup>-1</sup> plant<sup>-1</sup>.

### 3.2.2. Fresh and dry weight of root:

Figs. 7a and b show fresh and dry weight of root of lettuce plants grown in different source of nutrients (stock nutrient solution and effluent fish farm), different hydroponic systems (A shape, Gutter and Deep water systems) and different flow rates (1.0, 1.5 and 2.0 L h<sup>-1</sup> plant<sup>-1</sup>) at the end of experimental period. The results indicate that the fresh weight of root of lettuce plants values 81.28, 72.62 and 84.95 and 76.48, 77.44 and 69.35 g plant<sup>-1</sup> for 1.0, 1.5 and 2.0 L h<sup>-1</sup> plant<sup>-1</sup>, respectively, in nutrients solution and water discharged of the fish farm, respectively, for A shape hydroponic system. For gutter hydroponic system, the fresh weight of root of lettuce plants values were 81.34, 92.87 and 87.95 and 75.34, 85.73 and 74.65 g plant<sup>-1</sup> for 1.0, 1.5 and 2.0 L h<sup>-1</sup> plant<sup>-1</sup>, respectively, in nutrients solution and water discharged of the fish farm, respectively. While, the fresh weight of root of lettuce plants values were 68.75, 94.54 and 70.69 and 69.02, 80.16 and 59.19 g plant<sup>-1</sup> for 1.0, 1.5 and 2.0 L h<sup>-1</sup> plant<sup>-1</sup>, respectively, in nutrients solution and water discharged of the fish farm, respectively, for deep water hydroponic system.

The results also indicate that the dry weight of root of lettuce plants values 8.17, 7.69 and 9.14 and 7.44, 8.75 and 7.31 g plant<sup>-1</sup> for 1.0, 1.5 and 2.0 L h<sup>-1</sup> plant<sup>-1</sup>, respectively, in nutrients solution and water discharged of the fish farm, respectively, for A shape hydroponic system. For gutter hydroponic system, the dry weight of root of lettuce plants values were 7.94, 8.33 and 8.99 and 7.63, 9.07 and 8.78 g plant<sup>-1</sup> for 1.0, 1.5 and 2.0 L h<sup>-1</sup> plant<sup>-1</sup>, respectively, in nutrients solution and water discharged of the fish farm, respectively. While, the dry weight of root of lettuce plants values were 7.21, 10.29 and 7.32 and 6.79, 8.23 and 6.92 g plant<sup>-1</sup> for 1.0, 1.5 and 2.0 L h<sup>-1</sup> plant<sup>-1</sup>, respectively, in nutrients solution and water discharged of the fish farm, respectively, for deep water hydroponic system.

The results indicate that the highest values of fresh and dry weight of root (94.54 and 10.29 g plant<sup>-1</sup>) were found with gutter hydroponic system and 1.5 L h<sup>-1</sup> plant<sup>-1</sup> of flow rate, while, the lowest values of fresh and dry weight of root (59.19 and 6.79 g plant<sup>-1</sup>) were found with deep water hydroponic system and 1.0 L h<sup>-1</sup> plant<sup>-1</sup> of flow rate.

### 3.3. Nutrients uptake:

Figs. 8a, b, c, d and e show the nitrogen (N), phosphorus (P), potassium (K), calcium (Ca) and magnesium (Mg) uptake by lettuce plants at the end of experimental period in source of nutrients (stock nutrient solution and effluent fish farm), different hydroponic systems (A shape, Gutter and Deep water systems) and different flow rates (1.0, 1.5 and 2.0 L h<sup>-1</sup> plant<sup>-1</sup>).

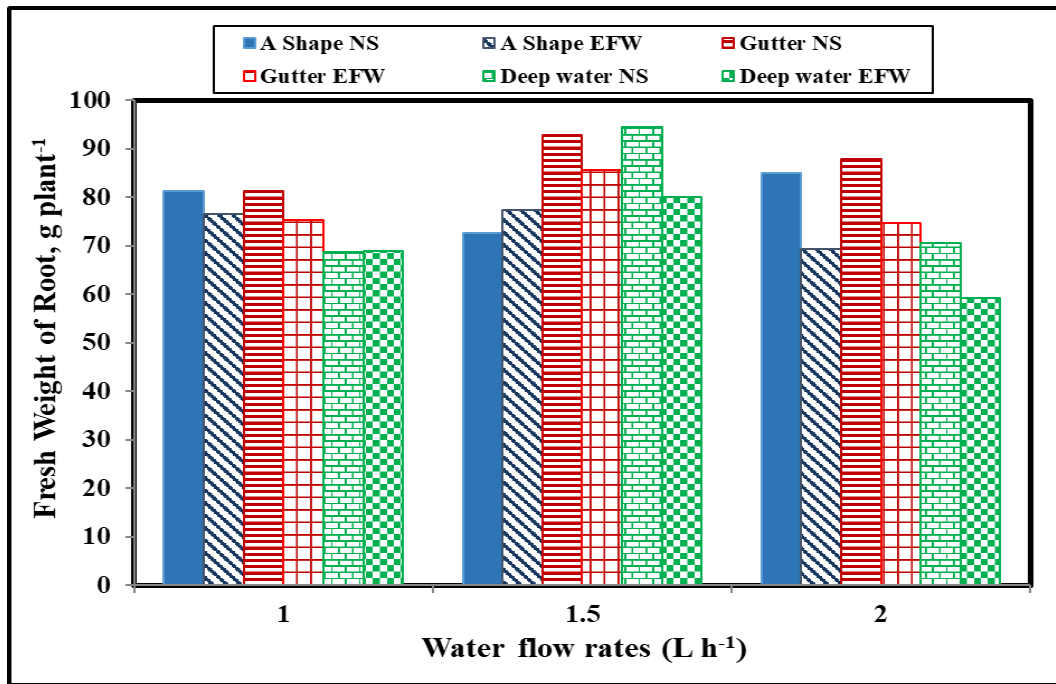

Fig. 7a: The fresh weight of root of lettuce plants.

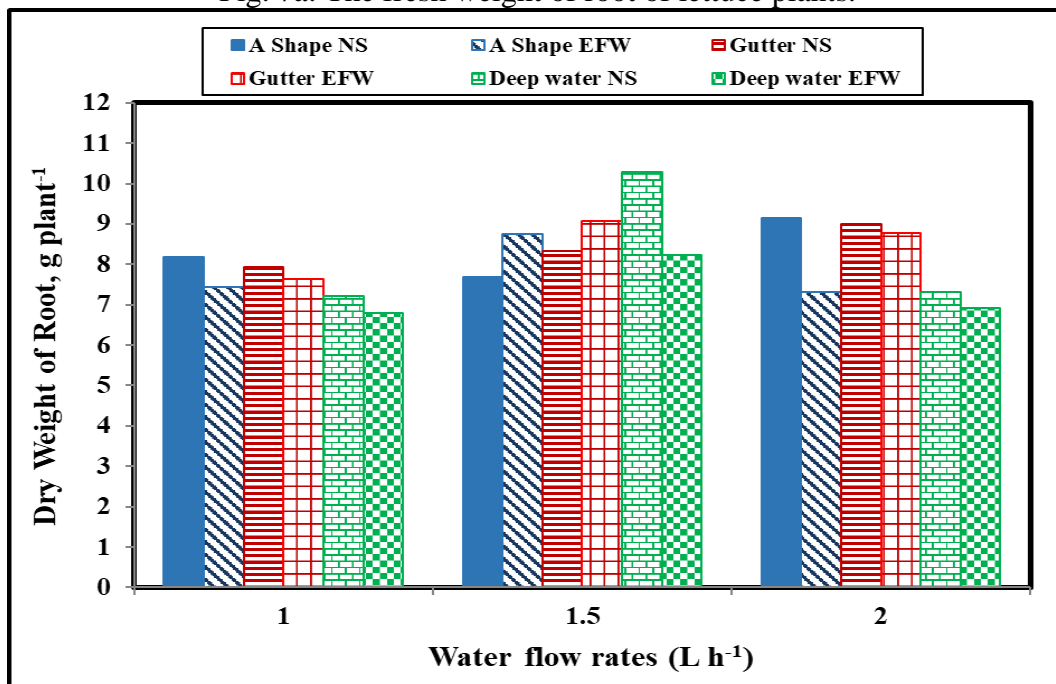
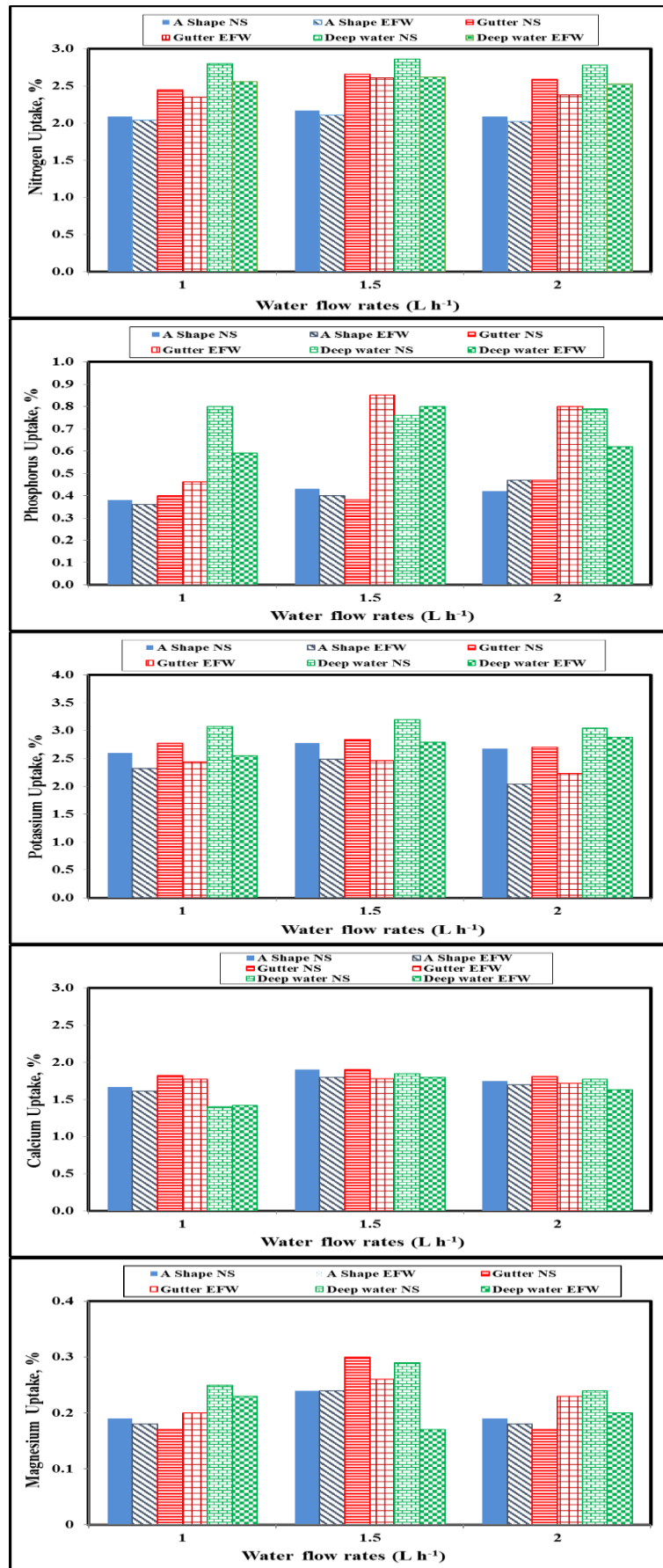

Fig. 7b: The dry weight of root of lettuce plants.

The results indicate that the nitrogen (N) uptake by lettuce plants values were 2.09, 2.17 and 2.09 and 2.04, 2.11 and 2.02 % for 1.0, 1.5 and 2.0 L h<sup>-1</sup> plant<sup>-1</sup>, respectively, in nutrients solution and water discharged of the fish farm, respectively, for A shape hydroponic system. For gutter hydroponic system, the nitrogen (N) uptake by lettuce plants values were 2.45, 2.66 and 2.59 and 2.35, 2.61 and 2.38 % for 1.0, 1.5 and 2.0 L h<sup>-1</sup> plant<sup>-1</sup>, respectively, in nutrients solution and water discharged of the fish farm, respectively. While, the nitrogen (N) uptake by lettuce plants values were 2.80, 2.86 and 2.78 and 2.56, 2.62 and 2.53 % for 1.0, 1.5 and 2.0 L h<sup>-1</sup> plant<sup>-1</sup>, respectively, in nutrients solution and water discharged of the fish farm, respectively, for deep water hydroponic system.



a

b

c

d

e

Fig. 8: Nutrients uptake by lettuce plants at the end of experimental period  
 a: Nitrogen b: Phosphorus c: Potassium d: calcium e: Magnesium

The phosphorus (P) uptake by lettuce plants values were 0.38, 0.43 and 0.47 and 0.6, 0.40 and 0.42 % for 1.0, 1.5 and 2.0 L h<sup>-1</sup> plant<sup>-1</sup>, respectively, in nutrients solution and water discharged of the fish farm, respectively, for A shape hydroponic system. For gutter hydroponic system, the phosphorus (P) uptake by lettuce plants values were 0.46, 0.85 and 0.80 and 0.40, 0.38 and 0.47 % for 1.0, 1.5 and 2.0 L h<sup>-1</sup> plant<sup>-1</sup>, respectively, in nutrients solution and water discharged of the fish farm, respectively. While, the phosphorus (P) uptake by lettuce plants values were 0.80, 0.802 and 0.79 and 0.59, 0.76 and 0.62 % for 1.0, 1.5 and 2.0 L h<sup>-1</sup> plant<sup>-1</sup>, respectively, in nutrients solution and water discharged of the fish farm, respectively, for deep water hydroponic system.

The potassium (K) uptake by lettuce plants values were 2.60, 2.78 and 2.68 and 2.32, 2.49 and 2.04 % for 1.0, 1.5 and 2.0 L h<sup>-1</sup> plant<sup>-1</sup>, respectively, in nutrients solution and water discharged of the fish farm, respectively, for A shape hydroponic system. For gutter hydroponic system, the potassium (K) uptake by lettuce plants values were 2.78, 2.84 and 2.70 and 2.44, 2.46 and 2.23 % for 1.0, 1.5 and 2.0 L h<sup>-1</sup> plant<sup>-1</sup>, respectively, in nutrients solution and water discharged of the fish farm, respectively. While, the potassium (K) uptake by lettuce plants values were 3.07, 3.20 and 3.05 and 2.55, 2.79 and 2.88 % for 1.0, 1.5 and 2.0 L h<sup>-1</sup> plant<sup>-1</sup>, respectively, in nutrients solution and water discharged of the fish farm, respectively, for deep water hydroponic system.

The calcium (Ca) uptake by lettuce plants values were 1.67, 1.90 and 1.75 and 1.61, 1.80 and 1.70 % for 1.0, 1.5 and 2.0 L h<sup>-1</sup> plant<sup>-1</sup>, respectively, in nutrients solution and water discharged of the fish farm, respectively, for A shape hydroponic system. For gutter hydroponic system, the calcium (Ca) uptake by lettuce plants values were 1.82, 1.90 and 1.81 and 1.77, 1.78 and 1.72 % for 1.0, 1.5 and 2.0 L h<sup>-1</sup> plant<sup>-1</sup>, respectively, in nutrients solution and water discharged of the fish farm, respectively. While, the calcium (Ca) uptake by lettuce plants values were 1.42, 1.85 and 1.77 and 1.40, 1.80 and 1.63 % for 1.0, 1.5 and 2.0 L h<sup>-1</sup> plant<sup>-1</sup>, respectively, in nutrients solution and water discharged of the fish farm, respectively, for deep water hydroponic system.

The magnesium (Mg) uptake by lettuce plants values were 0.19, 0.24 and 0.19 and 0.18, 0.24 and 0.18 % for 1.0, 1.5 and 2.0 L h<sup>-1</sup> plant<sup>-1</sup>, respectively, in nutrients solution and water discharged of the fish farm, respectively, for A shape hydroponic system. For gutter hydroponic system, the magnesium (Mg) uptake by lettuce plants values were 0.20, 0.30 and 0.23 and 0.17, 0.26 and 0.17 % for 1.0, 1.5 and 2.0 L h<sup>-1</sup> plant<sup>-1</sup>, respectively, in nutrients solution and water discharged of the fish farm, respectively. While, the magnesium (Mg) uptake by lettuce plants values were 0.25, 0.29 and 0.24 and 0.23, 0.17 and 0.20 % for 1.0, 1.5 and 2.0 L h<sup>-1</sup> plant<sup>-1</sup>, respectively, in nutrients solution and water discharged of the fish farm, respectively, for deep water hydroponic system.

Regarding the flow rate, the results indicate that the highest values of whole plant weight were found with 1.5 L h<sup>-1</sup>. It could be seen that, the highest values of N, P, K, Ca and Mg uptake were 2.86, 0.85, 3.20, 1.90 and 0.30 %, respectively, for all treatments. Increasing the nutrients uptake by lettuce plant were concomitant with increasing fresh and dry mass of shoot with a flow rate of 1.5 L h<sup>-1</sup> for hydroponic system, may be due to increasing in nutrient consumption rate. These results agreed with those obtained by **Khater and Ali (2015)**. Also,

the variation of nutrients uptake by root is attributed to nutrient concentration close to its surface, diffusion of nutrients through the root surface, interactions between nutrients and selectivity. It could be indicated that nutrient solution use was more efficient as compared with water discharged from the fish farm under different flow rate. These results were in agreement with (Adams, 1992).

### 3.1. Fish growth parameters

Table 2 shows the biological parameters (weight gain, fish growth rate, specific growth rate, feed conversion ratio and feed efficiency ratio) at the end of experimental period. The results indicate that the total weight gain, fish growth rate and specific growth rate were 138.9 g, 2.78 g day<sup>-1</sup> and 2.03 %, respectively. The results also, indicate that the feed fed, feed conversion ratio and feed efficiency ratio were 186.8 g fed g<sup>-1</sup> fish, 1.34 g feed g feed<sup>-1</sup> and 0.75 g fish g feed<sup>-1</sup>.

Table 2: The biological parameters of fish at the end of experimental period

Item	Value
Initial weight, g	79.23
Final weight, g	218.13
Total weight gain, g	138.9
FGR, g day <sup>-1</sup>	2.78
SGR, %	2.03
Feed fed, g/fish	186.8
FCR, g feed/g fish	1.34
FER, g fish/g feed	0.75

## 4. CONCLUSION

The experiment was carried out to study the integration between aquaculture and hydroponic systems to improve the growth and production of lettuce plants. To achieve that study the effect of different flow rate (1.0, 1.5 and 2.0 L h<sup>-1</sup>) and culture system (A shape, gutter and deep water) on root length, fresh and dry weight of shoot and root and nutrients uptake for lettuce plants in hydroponic and aquaponic systems. The obtained results can be summarized as follows:

- The highest value of the length of root (26.93 cm) was found with waste fish farm for deep water hydroponic system. However, the lowest value of was found to be 23.75 cm with nutrient solution for A shape hydroponic system.
- The highest values of fresh and dry weight of shoot (315.82 and 24.09 g plant<sup>-1</sup>) were found with gutter hydroponic system and 1.5 L h<sup>-1</sup> plant<sup>-1</sup> of flow rate, while, the lowest values of fresh and dry weight of shoot (176.33 and 14.08 g plant<sup>-1</sup>) were found with deep water hydroponic system and 1.0 L h<sup>-1</sup> plant<sup>-1</sup> of flow rate.
- The highest values of N, P, K, Ca and Mg uptake were 2.86, 0.85, 3.20, 1.90 and 0.30 %, respectively, for all treatments.
- The total weight gain, fish growth rate and specific growth rate were 138.9 g, 2.78 g day<sup>-1</sup> and 2.03 %, respectively.

## **5. REFERENCES**

- Adams, P. (1992).** Crop nutrition in hydroponics. *Acta Hort.*, 323: 289- 306
- Bremner, J. M. and Mulvaney C.S. (1982).** Nitrogen-total. In: Page, A.L., Miller, R.H., Keeney, D.R. (Eds.), *Methods of Soil Analysis, Part 2. Chemical and Microbiological Properties*, second ed., Agronomy series No. 9 ASA, SSSA, Madison, WI, pp. 595–624.
- Chapman, H.D. and Partt F.P. (1961).** *Methods of analysis of soils, plant and water*. Cal. Univ., 150-200.
- Delaide, B., Goddek S., Mankasingh U., Ragnarsdottir K.V., Jijakli H. and Thorarinsdottir R. (2015).** Challenges of sustainable and commercial aquaponics. *Sustain*, 7: 4199 – 4224.
- Ensink, H.H., Mehmood T., Vandder H.W., Raschid-Sally L. and Amerasinghe F.P. (2004).** A nation-wide assessment of wastewater use in Pakistan: an obscure activity or a vitally important one? *Water Policy* 6: 197 – 206.
- Genuncio, G.C., Gomes M., Ferrari A.C., Majerowiczand N. and Zonta E. (2012).** Hydroponic lettuce production in different concentrations and flow rates of nutrient solution. *Horticultural Brasília*, 30: 526-530.
- Graber, A. and Junge R. (2009).** Aquaponic systems: nutrient recycling from fish wastewater by vegetable production. *Desalination*, 246 (1–3), 147–156.
- Hollyer, J., Tamaru C., Riggs A., Klinger-Bowen R., Howerton R., Okimoto D., Castro L., Ron T., Fox B.K., Troegner V. and Martinez G. (2009).** *On-Farm FoodSafety: Aquaponics*. vol. 38. College of Tropical Agriculture and Human Resources, University of Hawaii at Manoa Food Safety and Technology, FST, pp. 1–7.
- Hussain, T., Verma A.K., Tiwari V.K., Chandra G., Shete, A.P. and Saharan N. (2014).** Effect of water flow rates on growth of *Cyprinus carpio varkoi* (*Cyprinus carpio L., 1758*) and spinach plant in aquaponic system. *Aquacult. Int.*, 22: 4 – 6.
- Jauncey, K. and Ross B. (1982).** *A guide to tilapia feeds and feeding*. Institute of aquaculture, university of sterling, Scotland. 111 pp.
- Keraita, B.N. and Drechsel P. (2004).** Agricultural use of untreated urban wastewater in Ghana. In: Scott, C.A., Faruqui, N.I., Raschid-Sally, L. (Eds.), *Wastewater Use in Irrigated Agriculture*. CABI Publishing, Wallingford, UK, pp. 101–112.
- Khater, E.G. (2006).** *Aquaponics: the integration of fish and vegetable culture in recirculating systems*. M. Sc. Thesis, in Agric. Eng., Fac. Agric., Moshtohor, Benha Univ., Egypt.
- Khater, E.G. (2016).** Effect of the ecological system on lettuce production grown under different soilless systems. *Misr J. Ag. Eng.*, 33(4): 1595-1614.
- Khater, E.G. (2012).** *Simulation model for design and management of water recirculating systems in aquaculture*. Ph. D., Thesis, Fac. Agric., Moshtohor, Benha Univ., Egypt.



- Khater, E.G. and Ali S.A. (2015).** Effect of flow rate and length of gully on lettuce plants in aquaponic and hydroponic systems. *J. of Aquac. Res. and Devel.*, 6: 3.
- Khater, E.G., Bahnasawy A.H., Abass W., Morsy O., El-Ghobashy H.M.T., Shaban Y. and Egela M.E. (2021).** Production of basil (*Ocimum basilicum* L.) under different soilless cultures. *Scientific Reports*, 11(12754): 1-14. DOI: [10.1038/s41598-021-91986-7](https://doi.org/10.1038/s41598-021-91986-7)
- Khater, E.G., Bahnasawy A.H., Shamsa A.S., Hassaan M.S. and Hassan Y.A. (2015).** Utilization of Effluent Fish Farms in Tomato Cultivation. *Eco. Eng.*, 83: 199 - 207.
- Klinger, D. and Naylor R. (2012).** Searching for solutions in aquaculture: charting a sustainable course. *Annu. Rev. Environ. Resour.*, 37: 247 – 276.
- Lennard, W.A. and Leonard B.V. (2006).** A comparison of three different hydroponic subsystems (gravel bed, floating and nutrient film technique) in an aquaponic test system. *Aquacult. Int.*, 14 (6): 539 – 550.
- Maucieri, C., Nicoletto C., Zanin G., Birolo M., Trocino A., Sambo P., Borin1 M. and Xiccato G. (2019).** Effect of stocking density of fish on water quality and growth performance of European Carp and leafy vegetables in a low-tech aquaponic system. *PLOS ONE*, 14(5): e0217561. <https://doi.org/10.1371/journal.pone.0217561>
- Murphy, J. and Riley J.P. (1962).** A modified single solution method for determination of phosphate in natural waters. *Anal. Chem. Acta*, 27: 31–36.
- Rakocy, J.E. (1989).** Tank culture of tilapia. In the biology and culture of tilapia, ed. R. S. V. Pullin & R. H. Lowe-McConnell-ICLARM conference proceedings 7. International center for living aquatic resources management, manila, the Philippines.
- Rakocy, J.E. (2012).** Aquaponics-Integrating Fish and Plant Culture. Wiley-Blackwellpp. 344–386.
- Rakocy, J.E. and Hargreaves J.A. (1993).** Integration of vegetable hydroponics with fish culture: a review. In: *Techniques for Modern Aquaculture, Proceedings Aquacultural Engineering Conference*. St. Joseph, MI, USA. American Society of Agricultural Engineers. pp. 112–136.
- Tucker, C. S. and Boyd C.E. (1985).** Water quality, channel catfish culture. In: C. S. Tucker (ed). Elsevier Sci. Publ. Co., Amsterdam, The Nether lands.

## الاستفادة من المياه الخارجة من المزارع السمكية في انتاج الخس

أميرة عبد الناصر أمين<sup>١</sup> السيد جمعة خاطر<sup>٢</sup>، سمير أحمد علي<sup>٣</sup> و صلاح محمد كمال<sup>٤</sup>

<sup>١</sup> طالبة دكتوراه - قسم هندسة النظم الزراعية والحيوية - كلية الزراعة - جامعة بنها - مصر.

<sup>٢</sup> أستاذ مساعد - قسم هندسة النظم الزراعية والحيوية - كلية الزراعة - جامعة بنها - مصر.

<sup>٣</sup> أستاذ - قسم هندسة النظم الزراعية والحيوية - كلية الزراعة - جامعة بنها - مصر.

<sup>٤</sup> أستاذ ووكيل المعمل المركزي لبحوث الثروة السمكية - مصر.

### الملخص العربي

يهدف هذا البحث إلى دراسة مدى كفاية العناصر الموجودة في مياه المزارع السمكية لتغذية النباتات وتحديد مقدار الاستفادة من الأسمدة النيتروجينية التي تخرج من مياه المزارع السمكية في تغذية نباتات الخس وأثر ذلك على تقليل استخدام الأسمدة الكيميائية والحفاظ على المياه وتحسين نمو النبات مما يؤدي إلى زيادة العائد الاقتصادي من هذه الدراسة. وتم إجراء هذه التجربة في وحدة المزرعة السمكية والبيوت المحمية - كلية الزراعة بمشتهر - جامعة بنها - محافظة القليوبية، لدراسة تأثير مصدران للمحلول المغذي (المحلول المغذي المجهز صناعياً والمياه الخارجة من المزرعة السمكية) وثلاث نظم للزراعة وهي نظام زراعة على شكل حرف A ونظام الزراعة في المجاري (Gutter) ونظام الزراعة في الحوض العميق (Deep water)، وثلاثة تصرفات للمياه وهي ١,٠ و ١,٥ و ٢,٠ لتر لكل نبات في الساعة على معدل طول الجذر لنبات الخس والوزن الطازج والجاف للمجموع الخضري والجذري ومعدل امتصاص العناصر. وكانت أهم النتائج المتحصل عليها كما يلي: كانت أعلى قيمة لطول جذر نبات الخس هي ٢٦,٩٣ سم مع نظام الزراعة (Deep water). وكان الوزن الطازج والجاف للمجموع الخضري والمجموع الجذري لنباتات الخس في نظام الزراعة في المجري (Gutter) ومعدل تصرف ١,٥ لتر لكل نبات في الساعة أفضل مقارنة بباقي المعاملات. وكانت أعلى قيمة لكل من النيتروجين والفوسفور والبوتاسيوم والكالسيوم والماغنسيوم لنباتات الخس هي ٢,٨٦ و ٠,٨٥ و ٣,٢٠ و ١,٩٠ و ٠,٣٠% على الترتيب، لكل المعاملات تحت الدراسة. وكان الوزن الكلي المكتسب ومعدل نمو الأسماك ومعدل النمو النوعي هي ١٣٨,٩ جم و ٢,٧٨ جم يوم<sup>-١</sup> و ٢,٠٣% على الترتيب.

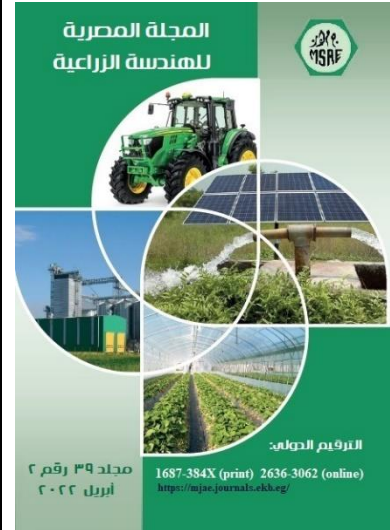

© المجلة المصرية للهندسة الزراعية

### الكلمات المفتاحية:

الزراعة المائية؛ الأسماك؛ الخس؛ طول الجذر؛ المجموع الخضري؛ المجموع الجذري؛ الوزن المكتسب.