

A DEVELOPED MACHINE TO HARVEST CARROT CROP

Horia, M. Abd El-Gany¹

E.A. El-Sahhar²

M.M. Mostafa²

F.A. Abd-Elhady³

ABSTRACT

The aim of the present study is to develop a rationalized power consumption carrot harvesting machine to be suitable for the Egyptian agricultural conditions. The developing machine components are namely: pulling unit, transmission system and frame. The present study consider that:- (1) Some physical and mechanical properties of foliage and root (dimensions, mass, pulling force, and tension force) and some soil properties. (2) Manufacturing the proposed harvester by relating dimensions design to the theoretical considerations. (3) Evaluating the mechanical of the developed harvester as affected by different design parameters. The machine forward speed 0.3 m/s. It was evaluated under operating parameters: pulling inclination angle, pulling belt speed and the height of branch catch. Meanwhile, the machine performance can be determined from crop quality, lifting efficiency and root damage. The obtained results concluded that the optimum parameters of the carrot harvesting machine were belt speed 0.5, belt inclination angle 45°, Height of branch catch 5 cm can be used to obtain the best root quality, root damage and lifting efficiency were 99.5, 0.5 and 86.46 % respectively.

INTRODUCTION

Carrot (*Dacus Carota*, L.) originated from middle Asia approximately 3,000 years ago and is a cash crop of economic importance in vegetable producing countries such as the United States and Japan. The vegetable is consumed in the fresh state (as salad ingredient), as processed canned

Eng. Agric. Eng. Res. Inst.

Prof of Agric. Eng. Dept. Ain Shams Univ

Senior Res. in Agric. Eng. Res. Inst.

peeled carrot or as a dehydrated product usually as a constituent of soup powder and flavoring for convenience foods. Carrots are rich sources of dietary fiber as well as beta-carotene, which the body converts to Vitamin A. Therefore, in Egypt the cultivated area of carrot was 10218 feddan, and its production was about 121333 ton (Ministry of agricultural 2005).

Honma et al. (1974) stated that progress made in vegetable breeding during the last three decades, is surveyed social change affected breeding. Objectives of depending on mechanization development of varieties which are suitable for mechanical harvesting and are uniform in maturity carrot, tomato and phaseolus. Which have been developed for mechanized harvesting.

Bajkin (1984) stated that the mechanized picking of carrot, parsley, parsnip and celery. Root losses quality of performed work, explosion indicators (consumption of man labor and machine work) depending on using machines (combines root diggers) were determined for each vegetable crop.

Guarnieri (1989) studied that, to be economically the new generation of vegetable crop harvesters require to be used on mechanical harvesting will become more important to reduce the problems of crop spoilage between harvesting and point of sale electronic control systems choice of cultivar suitable for mechanical harvesting, transporting and grading are some of the developments to expected in the fairly near future crops discussed include tomatoes, artichokes, peppers, cauliflowers, carrot and spinach.

Leunov (1989) found that vegetable growing as part of the agricultural system discussed with special reference to mechanization. The history of field equipment in the USSR is briefly reviewed and development of new generations of machines to modernize cultural system is mentioned on the economic effectiveness of cabbage, carrot, beet root and onion production by system based on harvesting machines of different working widths (4.2 and 5.4 m).

Millington (1984) found that mechanical damage during lifting and processing in the packhouse leads to the loss ranges from 20 – 50 % of the roots harvested and packhouse the lines were examined to assess the type and degree of damage caused.

Bar et al.(1988) stated that carrot production on very wide ridge using the field power unit (FPU) and on conventional ridge using conventional tractors was compared. The yield of carrot ranged from 4.2 ton/fed to 7.14 ton/fed. Depending on the wide ridge. The loss was mainly attributable to problems on steering the mechanical harvester.

Zufanak and goda (1990) stated that five cultivars of carrot were used in experiment and assessing the efficiency of an Em -11 one- row carrot harvester pulled by tractor. They found that the harvester performs better in plots with higher crop density decreasing the root damage at the same time.

Ozarsan et al. (1990) stated that the possibilities of harvesting carrots mechanically in Turkey were investigated to reduce labor requirements and reduce harvesting losses which are incurred when carrots are ploughed up for manual harvesting.

El-Sherief (1996) and Khodeir (2002) concluded that the increasing forward speed increase cut and bruise roots while it decreased the lifting efficiency.

Mady (2001) found that the mechanical harvesting lead to decrease the percentage of scarified roots and cut roots by 39.55 and 51.39 %, respectively under mechanical planting. But it equal to 12.9 and 9.39 % lower than traditional planting system .The mechanical harvesting increased the percentage of undamaged roots by 14.11 and 7.88 % higher than traditional harvesting under mechanical and traditional planting systems.

Abd – Rabou (2004) concluded that by decreasing forward speed tended to decrease total damaged roots. It is clear that, increasing forward speed from 0.55 to 1.06 m/s tends to increase the total damaged roots from 4.51 to 5.4% . The highest value of the total damaged roots of 6.2% was obtained at forward of 1.06 m/s therefore, the lowest value of the total damaged 3.4%was obtained at forward speed of 0.55 m/s.

The aim of the present study is develop and evaluate the carrot harvesting machine to reduce the power requirement

MATERIALS AND METHODS

The developed harvester was constructed according to the theoretical relation ship and its implement includes three main units namely: pulling unit, transmission systems and main frame. The harvesting machine photography view, elevation and plane view shown in Figs. (1 and 2).

The construction details of the pulling unit was built and constructed locally according to the theoretical relation ship and fitted to the developed harvester. It was made of steel sheet fixed on the machine frame. The pulling unit consists of three main parts fixed by especial frame units namely pulling belt, hoops group and belt fixed unit. The machine forward speed is constant at 0.3 m/s. Also, the studied parameters were carried out in Kalabsho village Dakahlia governorate at 2006-2007. The experimental study were done at split plot design in three replicates. These parameters were five levels of pulling inclination angle (α) of 25, 30, 35, 40 and 45°, three levels of pulling belt speed (S) of 0.5, 1.0 and 1.5 m/s and three levels of the height of foliage catch (H) of 5, 10 and 15 cm.

The measurement were carried out to determine some physical and mechanical properties of carrot (root length (L), root maximum diameter (d_{max}), height of foliage (H), root mass (M), tension force (τ) and pulling force that were determined from random samples of carrot plant directly before harvesting to focus on the properties of design and operating basic. Then the properties of the soil such as ridge profile, penetration resistance, bulk density and moisture content are measured.

To evaluate the performance of the developed machine the following equation were used:

$$\text{Crop quality} = \frac{\text{Number of un - damaged roots}}{\text{Number of total root harvesting}} \times 100$$

$$\text{Liftinf efficiency} = \frac{\text{Number of lifting roots}}{\text{Total root number}} \times 100$$

$$\text{Root damage} = \frac{\text{Number of root damage}}{\text{Total root number}} \times 100$$



Fig. 1: A simple carrot harvester.

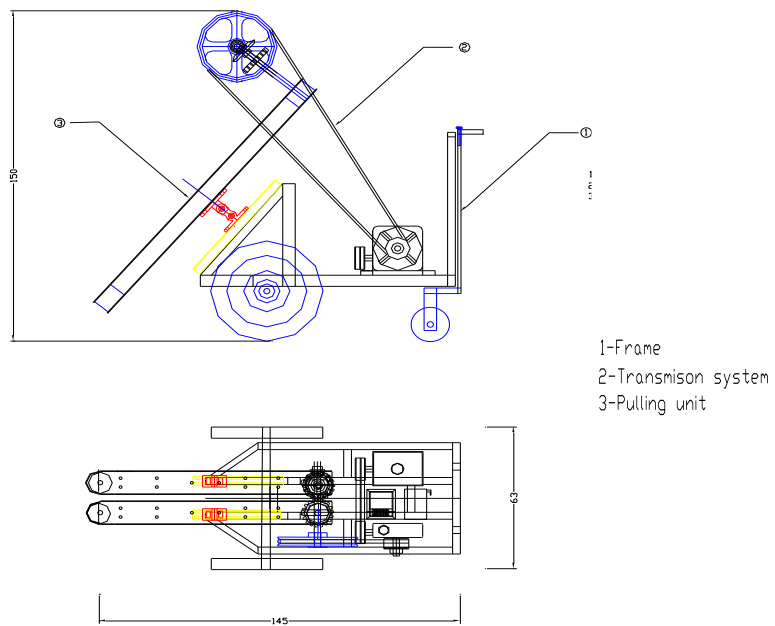

Fig. 2: An elevation and plan views of the carrot harvester.

RESULTS AND DISCUSSION

This study was conducted mainly to:

1- Some important properties of carrot plants

The important properties of carrot root were; length (L), diameter (d), mass (M), length of foliage (L_f), volume (V), foliage tensile force (T_f) and foliage tensile failure force (T_{ff}). Table (1) summarized the average and calculated some properties measurements of carrot plants.

Table 1: Some properties of carrot plant.

Properties	Average value
Length, mm	137.14 ± 29.23
Diameter, mm	31.30 ± 3.56
Mass, g	84.44 ± 15.13
Volume, cm^3	36.90 ± 16.25
Foliage length, mm	50.56 ± 4.87
Tensile force, N	84.20 ± 13.64
Tensile failure , N	127.10 ± 21.81

The data from table (1) cleared that the average of the main dimensions of the carrot are 137.14 ± 29.23 mm, 50.56 ± 4.87 mm, 31.30 ± 3.56 mm, 84.44 ± 15.13 N and 36.90 ± 16.25 cm^3 for carrot root and foliage lengths, diameter, mass and volume. Therefore, the foliage tensile failure increased about 42.9 N more than the foliage tensile forces.

2- Carrot ridge properties

The carrot ridge properties such as profile, penetration resistance, bulk density and moisture content, were measured directly before harvesting. The ridge profile is illustrated in Fig. (3). It cleared that the upper width of ridge was about 700 mm and its height of 130 mm. Therefore, the data in table (2) show that the average values of ridge properties, soil penetration resistance, bulk density and moisture content of 130 N, 1.34 g/cm^3 and 25 % respectively.

3. Evaluation the developed harvester under some operating parameters

a- Root quality

Fig. (4) clear that the effect of belt inclination angle on root quality at

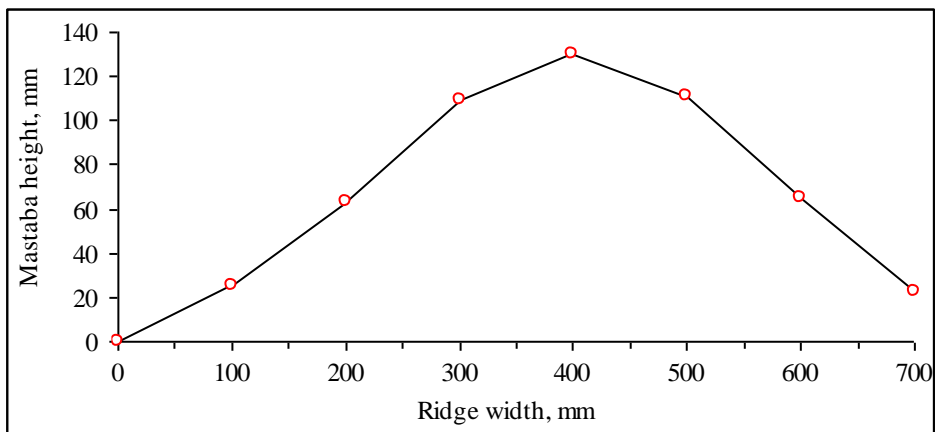

Fig. (3) Ridge profile of carrot plant.

Table 2: The soil physical and mechanical properties at different depth

Depth	Properties	Penetration resistance, N	Bulk density, g/cm ³	Moisture content, %
5		145	1.31	21
10		135	1.31	23
15		130	1.33	24
20		120	1.35	25
25		120	1.36	25

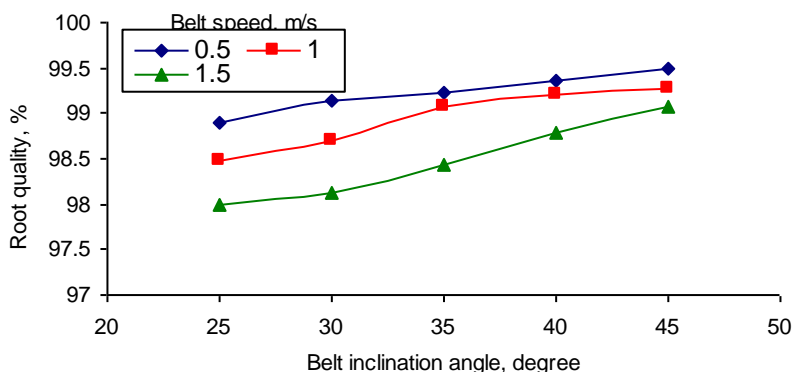

Fig. 4: The effect of belt inclination angle on root quality.

different belt speeds. From the figure the increasing in belt inclination angle from 25° to 45° the root quality increase from 98.90 to 99.5, 98.48 to 99.28 and 97.99 to 99.08 respectively at belt speeds of 0.5, 1.0 and 1.5 m/s. Therefore the data cleared that the root quality increased by decreasing the belt speed. However, the root quality increase as average from 98.49 to 98.22 % by the belt speed decrease from 1.5 to 0.5 m/s.

b- Root damage

Fig. (5) show that the relationship between belt inclination angle and root damage at different belt speeds. The figure illustrated that increasing belt inclination angle from 25° to 45° the root damage decrease from 1.0 to 0.5 at belt speed 0.5 m/s, 1.5 to 0.8 at belt speed 1.0 m/s and 2.0 to 1.0 at belt speed 1.5 m/s. Therefore the data cleared that the root damage increase as average from 0.77 to 1.51 % by increasing belt speed from 0.5 to 1.5 m/s.

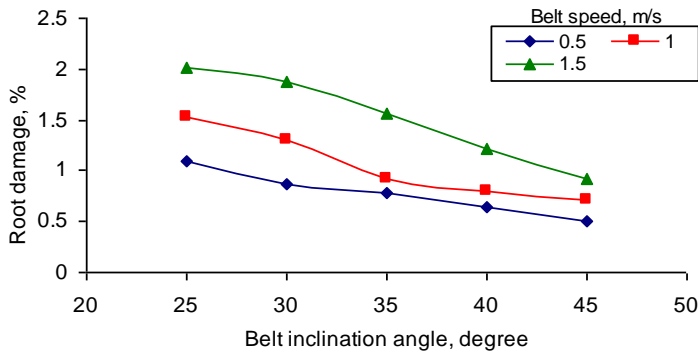

Fig. 5: The relationship between belt inclination angle and root damage.

c- Lifting efficiency

Fig. (6) clear that the effect of inclination angle on lifting efficiency at different belt speed and height of foliage catch. From the figure the increasing in belt inclination angle from 25° to 45° the lifting efficiency increase from 78 to 82, 76 to 80 and 73 to 76 % respectively at the belt speed 0.5, 1.0 and 1.5 m/s and height of foliage catch of 5 cm. On the other side, at the foliage catch 10 cm the figure (6) illustrate that the increasing in belt inclination angle from 25° to 45° the lifting efficiency increase from 69 to 73, 68 to 71 and 64 to 68 % respectively at belt speed 0.5, 1.0 and 1.5 m/s and at height of foliage catch of 10 cm. Therefore, the above figure show that the increasing in belt inclination angle from 25° to 45° the lifting efficiency increase from 68 to 73, 64 to 68 and 61 to 65 % respectively at speeds of 0.5, 1.0 and 1.5 m/s and at height of foliage catch of 15cm. Subsequently, the data cleared that the lifting efficiency increased by decrease the belt speed.

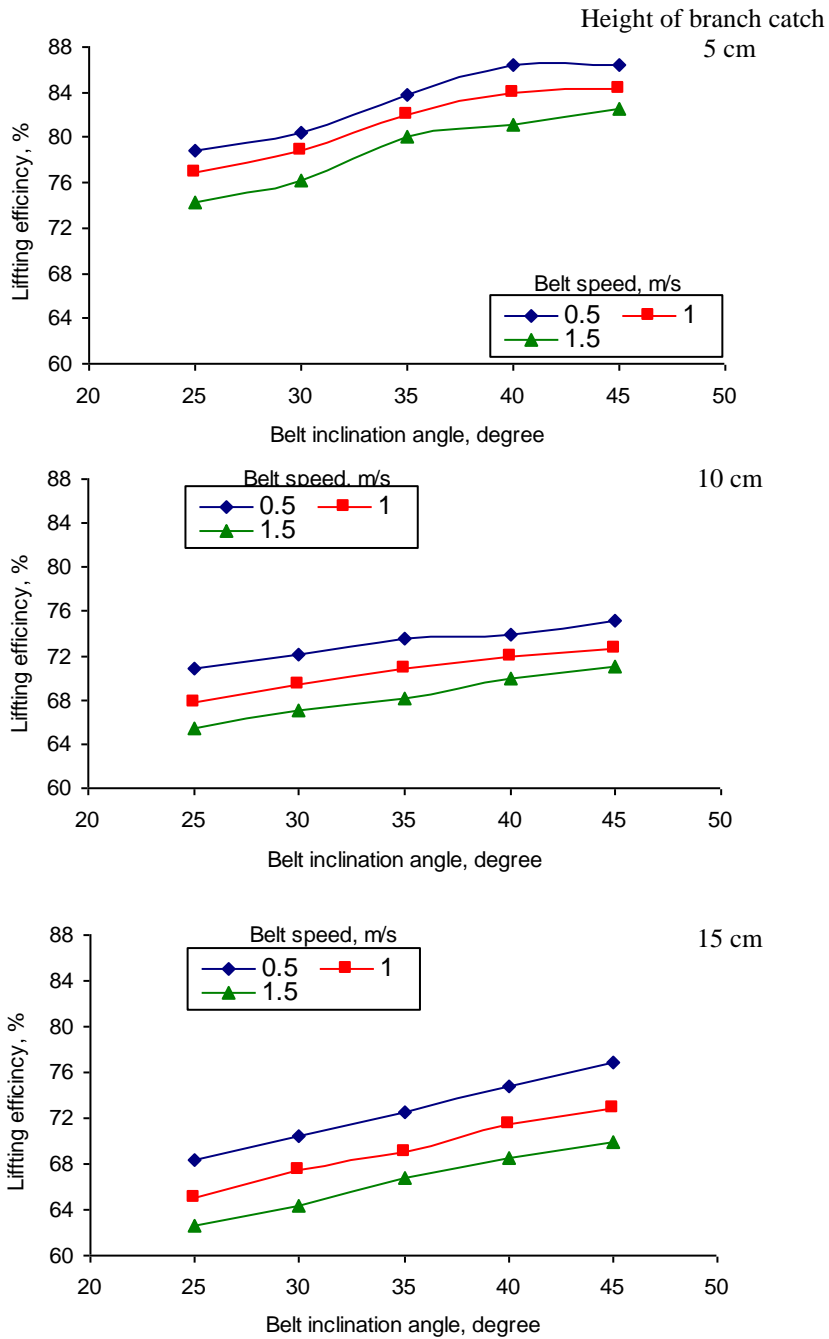

Fig. 6: The effect of inclination angle on lifting efficiency at different belt speed and different height of foliage catch.

On the other side the belt speed decreased from 1.5 to 0.5 the lifting efficiency increasing as average from 78.86 to 83.21, 68.30 to 73.13 and 66.42 to 72.56 % respectively at height of foliage catch 5, 10 and 15 cm. Meanwhile the lifting efficiency were 81.09, 70.66 and 69.38 % at height of foliage catch 5, 10 and 15 cm respectively.

CONCLUSION

From the obtained results the study can be concluded that the optimum parameters of the carrot harvesting machine were belt speed 0.5, belt inclination angle 45°, Height of branch catch 5 cm can be used to obtain the best root quality, root damage and lifting efficiency were 99.5, 0.5 and 86.46 % respectively.

REFERENCES

- Abd-Rabou, A.F. (2004). Manufacturing a small machine to suit harvesting sugar beet under Egyptian conditions. PhD Thesis Agric. Mech. Dept. Fac. of Agric. Kafr El-Sheikh. Tanta Univ.
- Bajkin, A. (1984). Evaluation of work quality and effect of machinery aggregates for digging root like vegetables, savremena- poljorivedna tehnika. (yugoslavia). 1984, vol. 10(12): 29-34
- El-Sherief, R.R.A. (1996). A study on harvesting mechanization of sugar beet. PhD Thesis Agric. Mech . Dept. Fac. of Agric. Kafr El-Sheikh. Tanta Univ.
- Guarnieri, A. (1989). The development of harvesters for vegetable crops. Machine -e-motroi Agricolill trattorista 1989, 47(2): 31-33.
- Honma, S.; R. Antoszewski and L. Harrison (1979). Implication of relevant genetic changes in vegetables. Proc. of the xix I.: Hort. Cong., III. Section VIII vegetables: 465-473.
- Leunov, L. L. (1989). Technology of vegetable production, theory and practice vestnik sel'skokozyzistvennionauki. Maskva, 5: 107-112.
- Mady, M. A. (2001). Mechanization of some operations for sugar beet production. Misr. J. Agric. Eng., 18 (2) : 339 – 355.
- Millington, S. (1984). Quality of carrots in the united kingobom with respect to harvester and packhouse damage. Acta. Hort. 163: 127-136.

- Ministry of Agriculture and Land Reclamation Economic Affairs Sector (EAS) (2005). Study of the indicators agricultural statistics. 85.
- Ozarlan, C; D. Erdogan and Y. Zeren (1990). Mechanization possibilities on carrot harvesting, I. Cong. Mee. and Energy inEgr. Proc. of cont. held in Adana, Turkey, 374-282.
- Zufanek, J. B. Groda (1990). The influence of the carrot crop organization on the harvesting equipment performance and quality of work. Zemedelska Technika. 36(1): 37-45.

الملخص العربي

تطوير آلة لحصاد محصول الجزر

م. حورية محمد عبد الغنى أحمد فضل^١ أ.د. عصام أحمد السحار^٢
أ.د. مبارك محمد مصطفى^٢ د. فتحي عبد الحليم عبد الهادي^٣

يهدف هذا البحث إلى تطوير آلة لحصاد الجزر تقلل من إستهلاك القدرة تناسب الظروف المصرية. هذه الآلة تصنع من خامات محلية وتعتمد من حيث التصميم على تقنية جذب وشد جذور الجزر (تقليع). وتتكون الآلة من وحدة تقليع الجذور، نظام نقل القدرة، والإطار. ومن خلال هذا البحث تم دراسة بعض الخواص الطبيعية والميكانيكية للجزر (الأبعاد الرئيسية للجذر، الكتلة، قوة الرفع، قوة الشد) وللتربة المحيطة (شكل الخط، مقاومة الإختراق، الكثافة الظاهرية، نسبة الرطوبة)، وذلك بهدف إستخدامها كقاعدة بيانات لتصميم وتشغيل أجزاء الآلة المختلفة. وقد تم إستخدام الآلة عند سرعة تقدم ٠,٣ م/ث، كما تم اختبار وتقييم أداء الآلة المطورة عند عوامل الدراسة (زاوية الرفع، سرعة السير، إرتفاع مسك العرش). وقد تم الحصول على أفضل نتائج لجودة الجذور (٩٩,٥%)، الجذور التالفة (٠,٥%)، كفاءة الحصاد (الرفع) (٨٦,٤٦%) عند زاوية رفع ٤٥°، سرعة سير ٠,٥ متر/ساعة، إرتفاع مسك العرش ٥ سم.

مهندسة بمعهد بحوث الهندسة الزراعية، مركز البحوث الزراعية.
أستاذة دكتور بكلية الزراعة – جامعة عين شمس.
باحث أول بمعهد بحوث الهندسة الزراعية، مركز البحوث الزراعية.